

CBSE EXAMINATION PAPER-2025

Physics (Theory)

Class-12th

(Solved)

(Delhi & Outside Delhi Sets)

Time : 3 Hours

Max. Marks : 70

General Instructions:

Read the following instructions carefully and follow them:

- This question paper contains 33 questions. All questions are compulsory.
- Question paper is divided into FIVE sections - Sections A, B, C, D and E.
- In Section A, Question numbers 1 to 16 are multiple choice questions (MCQs) type questions. Each question carries 1 mark.
- In Section B, Question numbers 17 to 21 are very short answer (VSA) type questions. Each question carries 2 marks.
- In Section C, Question numbers 22 to 28 are short answer (SA) type questions. Each question carries 3 marks.
- In Section D, Question numbers 29 & 30 are Case Study-Based questions. Each question carries 4 marks.
- In Section E, Question numbers 31 to 33 are Long Answer (LA) type questions. Each question carries 5 marks.
- There is no overall choice given in the question paper. However, an internal choice has been provided in few questions in all the Sections except Section A.
- Kindly note that there is a separate question paper for Visually Impaired candidates.
- Use of calculators is NOT allowed.

You may use the following values of physical constants wherever necessary:

$$c = 3 \times 10^8 \text{ m/s}$$

$$h = 6.63 \times 10^{-34} \text{ Js}$$

$$e = 1.6 \times 10^{-19} \text{ C}$$

$$\mu_0 = 4\pi \times 10^{-7} \text{ T m A}^{-1}$$

$$\epsilon_0 = 8.854 \times 10^{-12} \text{ C}^2 \text{ N}^{-1} \text{ m}^{-2}$$

$$\frac{1}{4\pi\epsilon_0} = 9 \times 10^9 \text{ N m}^2 \text{ C}^{-2}$$

$$\text{Mass of electron } (m_e) = 9.1 \times 10^{-31} \text{ kg.}$$

$$\text{Mass of neutron} = 1.675 \times 10^{-27} \text{ kg.}$$

$$\text{Mass of proton} = 1.673 \times 10^{-27} \text{ kg.}$$

$$\text{Avogadro's number} = 6.023 \times 10^{23} \text{ per gram mole}$$

$$\text{Boltzmann's constant} = 1.38 \times 10^{-23} \text{ JK}^{-1}$$

Delhi Set-1

55/1/1

SECTION - A

1. Figure shows variation of Coulomb force (F) acting between two point charges with $\frac{1}{r^2}$, r being the separation between the two charges (q_1, q_2) and (q_2, q_3). If q_2 is positive and least in magnitude, then the magnitudes of q_1, q_2 and q_3 are such that

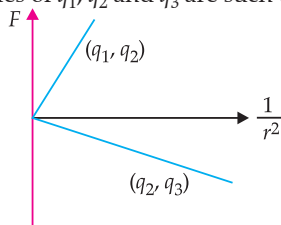

- (A) $q_2 < q_3 < q_1$ (B) $q_3 < q_1 < q_2$
(C) $q_1 < q_2 < q_3$ (D) $q_2 < q_1 < q_3$
2. Two wires P and Q are made of the same material. The wire Q has twice the diameter and half the length as that of wire P. If the resistance of wire P is

R , the resistance of the wire Q will be

- (A) R (B) $\frac{R}{2}$
(C) $\frac{R}{8}$ (D) $2R$

3. A 1 cm segment of a wire lying along x -axis carries current of 0.5 A along $+x$ direction. A magnetic field $\vec{B} = (0.4 \text{ mT})\hat{j} + (0.6 \text{ mT})\hat{k}$ is switched on, in the region. The force acting on the segment is
(A) $(2\hat{j} + 3\hat{k}) \text{ mN}$ (B) $(-3\hat{j} + 2\hat{k}) \mu\text{N}$
(C) $(6\hat{j} + 4\hat{k}) \text{ mN}$ (D) $(-4\hat{j} + 6\hat{k}) \mu\text{N}$
4. A coil has 100 turns, each of area 0.05 m^2 and total resistance 1.5Ω . It is inserted at an instant in a magnetic field of 90 mT, with its axis parallel to the field. The charge induced in the coil at that instant is
(A) 3.0 mC (B) 0.30 C
(C) 0.45 C (D) 1.5 C

5. You are required to design an air-filled solenoid of inductance 0.016 H having a length 0.81 m and radius 0.02 m. The number of turns in the solenoid should be

(A) 2592 (B) 2866
(C) 2976 (D) 3140

Note: The given options by the Board are not matched with questions.

6. A voltage $v = v_0 \sin \omega t$ applied to a circuit drives a current $i = i_0 \sin (\omega t + \phi)$ in the circuit. The average power consumed in the circuit over a cycle is

(A) Zero (B) $i_0 v_0 \cos \phi$
(C) $\frac{i_0 v_0}{2}$ (D) $\frac{i_0 v_0}{2} \cos \phi$

7. The given diagram exhibits the relationship between the wavelength of the electromagnetic waves and the energy of photon associated with them. The three points P, Q and R marked on the diagram may correspond respectively to

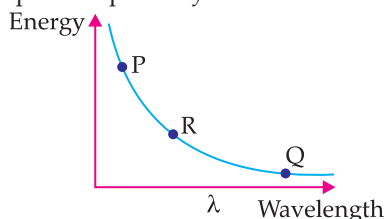

(A) X-rays, microwaves, UV radiation
(B) X-rays, UV radiation, microwaves
(C) UV radiation, microwaves, X-rays
(D) Microwaves, UV radiation, X-rays

8. A beaker is filled with water (refractive index $\frac{4}{3}$)

up to a height H . A coin is placed at its bottom. The depth of the coin, when viewed along the near normal direction, will be

(A) $\frac{H}{4}$ (B) $\frac{3H}{4}$
(C) H (D) $\frac{4H}{3}$

9. The stopping potential V_0 measured in a photoelectric experiment for a metal surface is plotted against frequency ν of the incident radiation. Let m be the slope of the straight line so obtained. Then the value of charge of an electron is given by (h is the Planck's constant)

(A) mh (B) $\frac{m}{h}$
(C) $\frac{h}{m}$ (D) $\frac{1}{mh}$

10. Let λ_e , λ_p and λ_d be the wavelengths associated with an electron, a proton and a deuteron, all moving with the same speed. Then the correct relation between them is

(A) $\lambda_d > \lambda_p > \lambda_e$ (B) $\lambda_e > \lambda_p > \lambda_d$
(C) $\lambda_p > \lambda_e > \lambda_d$ (D) $\lambda_e = \lambda_p = \lambda_d$

11. Which of the following figures correctly represents the shape of curve of binding energy per nucleon as a function of mass number?

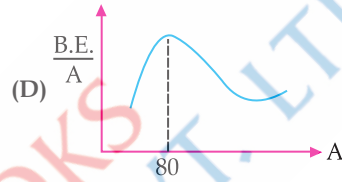
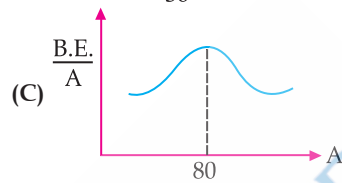
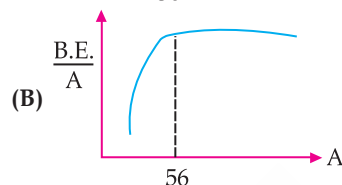
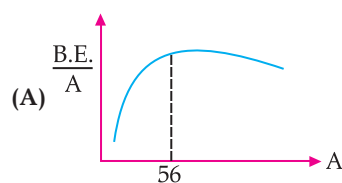

12. When a p - n junction diode is forward biased
- (A) the barrier height and the depletion layer width both increase.
(B) the barrier height increases and the depletion layer width decreases.
(C) the barrier height and the depletion layer width both decrease.
(D) the barrier height decreases and the depletion layer width increases.

Note:

Question numbers 13 to 16 are Assertion (A) and Reason (R) type questions. Two statements are given – one labelled Assertion (A) and the other labelled Reason (R). Select the correct answer from the codes (A), (B), (C) and (D) as given below:

- (A) Both Assertion (A) and Reason (R) are true and Reason (R) is the correct explanation of Assertion (A).
(B) Both Assertion (A) and Reason (R) are true, but Reason (R) is not the correct explanation of Assertion (A).
(C) Assertion (A) is true, but Reason (R) is false.
(D) Assertion (A) is false and Reason (R) is also false.

13. **Assertion (A):** It is difficult to move a magnet into a coil of large number of turns when the circuit of the coil is closed.

Reason (R): The direction of induced current in a coil with its circuit closed, due to motion of a magnet, is such that it opposes the cause.

14. **Assertion (A):** The deflection in a galvanometer is directly proportional to the current passing through it.

Reason (R): The coil of a galvanometer is suspended in a uniform radial magnetic field.

15. **Assertion (A):** We cannot form a p - n junction diode by taking a slab of a p -type semiconductor and physically joining it to another slab of a n -type semiconductor.

Reason (R): In a p -type semiconductor $n_e \gg n_i$ while in a n -type semiconductor $n_i \gg n_e$.

16. Assertion (A): The potential energy of an electron revolving in any stationary orbit in a hydrogen atom is positive.

Reason (R): The total energy of a charged particle is always positive.

SECTION – B

17. A battery of emf E and internal resistance r is connected to a rheostat. When a current of 2 A is drawn from the battery, the potential difference across the rheostat is 5 V. The potential difference becomes 4 V when a current of 4 A is drawn from the battery. Calculate the value of E and r .

18. (a) In a diffraction experiment, the slit is illuminated by light of wavelength 600 nm. The first minimum of the pattern falls at $\theta = 30^\circ$. Calculate the width of the slit.

OR

(b) In a Young's double-slit experiment, two light waves, each of intensity I_0 , interfere at a point, having a path difference $\frac{\lambda}{8}$ on the screen. Find the intensity at this point.

19. A transparent solid cylindrical rod (refractive index $\frac{2}{\sqrt{3}}$) is kept in air. A ray of light incident on its face travels along the surface of the rod, as shown in figure. Calculate the angle θ .

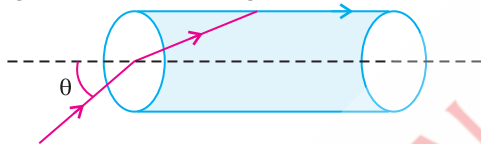

20. Prove that, in Bohr model of hydrogen atom, the time period of revolution of an electron in n^{th} orbit is proportional to n^3 .

21. A p -type Si semiconductor is made by doping an average of one dopant atom per 5×10^7 silicon atoms. If the number density of silicon atoms in the specimen is 5×10^{28} atoms m^{-3} , find the number of holes created per cubic centimetre in the specimen due to doping. Also give one example of such dopants.

SECTION – C

22. (a) Two batteries of emf's 3 V and 6 V and internal resistances 0.2Ω and 0.4Ω are connected in parallel. This combination is connected to a 4Ω resistor. Find:

- the equivalent emf of the combination
- the equivalent internal resistance of the combination
- the current drawn from the combination

OR

(b) (i) A conductor of length l is connected across an ideal cell of emf E . Keeping the cell connected, the length of the conductor is increased to $2l$ by gradually stretching it. If R and R' are initial and final values of resistance and v_d and v_d' are initial and final values of drift velocity, find the relation between

- R' and R and
- v_d' and v_d .

(ii) When electrons drift in a conductor from lower to higher potential, does it mean that all the 'free electrons' of the conductor are moving

in the same direction?

23. Using Biot-Savart law, derive expression for the magnetic field (B) due to a circular current carrying loop at a point on its axis and hence at its centre.

24. (a) Show that the energy required to build up the current I in a coil of inductance L is $\frac{1}{2}LI^2$.

(b) Considering the case of magnetic field produced by air-filled current carrying solenoid, show that the magnetic energy density of a magnetic field B is $\frac{B^2}{2\mu_0}$.

25. (a) A parallel plate capacitor is charged by an ac source. Show that the sum of conduction current (I_c) and the displacement current (I_d) has the same value at all points of the circuit.

(b) In case (a) above, is Kirchoff's first rule (junction rule) valid at each plate of the capacitor? Explain.

26. Answer the following giving reason:

(a) All the photo electrons do not eject with same kinetic energy when monochromatic light is incident on a metal surface.

(b) The saturation current in case (a) is different for different intensity.

(c) If one goes on increasing the wavelength of light incident on a metal surface, keeping its intensity constant, emission of photo electrons stop at a certain wavelength for this metal.

27. (a) Define 'Mass defect' and 'Binding energy' of a nucleus. Describe 'Fission process' on the basis of binding energy per nucleon.

(b) A deuteron contains a proton and a neutron and has a mass of 2.013553 u. Calculate the mass defect for it in u and its energy equivalence in MeV. ($m_p = 1.007277$ u, $m_n = 1.008665$ u, $1\text{u} = 931.5$ MeV/ c^2)

28. (a) Draw circuit arrangement for studying V - I characteristics of a p - n junction diode.

(b) Show the shape of the characteristics of a diode.

(c) Mention two information that you can get from these characteristics.

SECTION – D

Question numbers 29 and 30 are case study based questions. Read the following paragraphs and answer the questions that follow.

29. A circuit consisting of a capacitor C , a resistor of resistance R and an ideal battery of emf V , as shown in figure is known as RC series circuit.

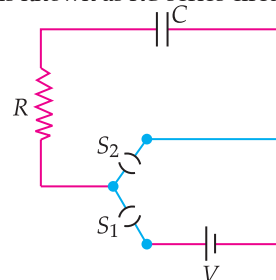

As soon as the circuit is completed by closing key S_1 (keeping S_2 open) charges begin to flow between the capacitor plates and the battery terminals. The charge on the capacitor increases and consequently the potential difference $V_c (= q/C)$ across the capacitor also increases

with time. When this potential difference equals the potential difference across the battery, the capacitor is fully charged ($Q = VC$). During this process of charging, the charge q on the capacitor changes with time t as $q = Q[1 - e^{-t/RC}]$

The charging current can be obtained by differentiating it and using $\frac{d}{dx}(e^{mx}) = me^{mx}$

Consider the case when $R = 20 \text{ k}\Omega$, $C = 500 \text{ }\mu\text{F}$ and $V = 10 \text{ V}$.

- (i) The final charge on the capacitor, when key S_1 is closed and S_2 is open, is
 (A) $5 \text{ }\mu\text{C}$ (B) 5 mC
 (C) 25 mC (D) 0.1 C
- (ii) For sufficient time the key S_1 is closed and S_2 is open. Now key S_2 is closed and S_1 is open. What is the final charge on the capacitor?
 (A) Zero (B) 5 mC
 (C) 2.5 mC (D) $5 \text{ }\mu\text{C}$
- (iii) The dimensional formula for RC is
 (A) $[M L^2 T^{-3} A^{-2}]$ (B) $[M^0 L^0 T^{-1} A^0]$
 (C) $[M^{-1} L^{-2} T^4 A^2]$ (D) $[M^0 L^0 T A^0]$
- (iv) The key S_1 is closed and S_2 is open. The value of current in the resistor after 5 seconds, is
 (A) $\frac{1}{2\sqrt{e}} \text{ mA}$ (B) $\sqrt{e} \text{ mA}$
 (C) $\frac{1}{\sqrt{e}} \text{ mA}$ (D) $\frac{1}{2e} \text{ mA}$

OR

- (iv) The key S_1 is closed and S_2 is open. The initial value of charging current in the resistor, is
 (A) 5 mA (B) 0.5 mA
 (C) 2 mA (D) 1 mA

30. A thin lens is a transparent optical medium bounded by two surfaces, at least one of which should be spherical. Applying the formula for image formation by a single spherical surface successively at the two surfaces of a lens, one can obtain the 'lens maker formula' and then the 'lens formula'. A lens has two foci – called 'first focal point' and 'second focal point' of the lens, one on each side.

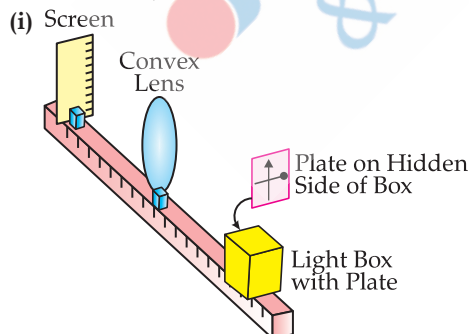

Consider the arrangement shown in figure. A black vertical arrow and a horizontal thick line with a ball are painted on a glass plate. It serves as the object. When the plate is illuminated, its real image is formed on the screen.

Which of the following correctly represents the image formed on the screen.

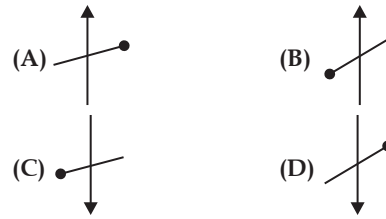

- (ii) Which of the following statements is incorrect.
 (A) For a convex mirror magnification is always negative.
 (B) For all virtual images formed by a mirror magnification is positive.
 (C) For a concave lens magnification is always positive.
 (D) For real and inverted images, magnification is always negative.
- (iii) A convex lens of focal length ' f ' is cut into two equal parts perpendicular to the principal axis. The focal length of each part will be
 (A) f (B) $2f$
 (C) $\frac{f}{2}$ (D) $\frac{f}{4}$
- OR
- (iii) If an object in case (i) above is 20 cm from the lens and the screen is 50 cm away from the object, the focal length of the lens used is
 (A) 10 cm (B) 12 cm
 (C) 16 cm (D) 20 cm
- (iv) The distance of an object from first focal point of a biconvex lens is X_1 and distance of the image from second focal point is X_2 . The focal length of the lens is
 (A) $X_1 X_2$ (B) $\sqrt{X_1 + X_2}$
 (C) $\sqrt{X_1 X_2}$ (D) $\sqrt{\frac{X_2}{X_1}}$

SECTION – E

31. (a) (i) Two point charges $5 \text{ }\mu\text{C}$ and $-1 \text{ }\mu\text{C}$ are placed at points $(-3 \text{ cm}, 0, 0)$ and $(3 \text{ cm}, 0, 0)$ respectively. An external electric field $\vec{E} = \frac{A}{r^2} \hat{r}$

where $A = 3 \times 10^5 \text{ Vm}$ is switched on in the region.

Calculate the change in electrostatic energy of the system due to the electric field.

- (ii) A system of two conductors is placed in air and they have net charge of $+80 \text{ }\mu\text{C}$ and $-80 \text{ }\mu\text{C}$ which causes a potential difference of 16 V between them.
 (1) Find the capacitance of the system.
 (2) If the air between the capacitor is replaced by a dielectric medium of dielectric constant 3, what will be the potential difference between the two conductors?
 (3) If the charges on two conductors are changed to $+160 \text{ }\mu\text{C}$ and $-160 \text{ }\mu\text{C}$, will the capacitance of the system change?
 Give reason for your answer.

OR

- (b) (i) Consider three metal spherical shells A, B and C , each of radius R . Each shell is having a concentric

metal ball of radius $R/10$. The spherical shells A, B and C are given charges $+6q$, $-4q$ and $14q$ respectively. Their inner metal balls are also given charges $-2q$, $+8q$ and $-10q$ respectively. Compare the magnitude of the electric fields due to shells A, B and C at a distance $3R$ from their centres.

- (ii) A charge $-6 \mu\text{C}$ is placed at the centre B of a semicircle of radius 5 cm, as shown in the figure. An equal and opposite charge is placed at point D at a distance of 10 cm from B. A charge $+5 \mu\text{C}$ is moved from point 'C' to point 'A' along the circumference. Calculate the work done on the charge.

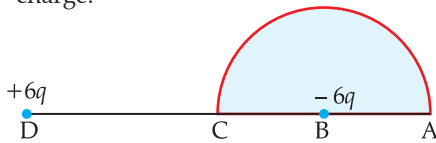

32. (a) (i) A proton moving with velocity \vec{V} in a non-uniform magnetic field traces a path as shown in the figure.

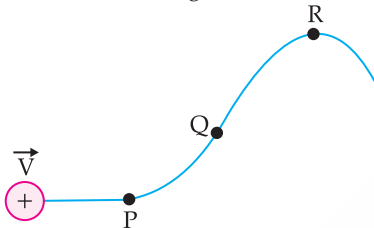

The path followed by the proton is always in the plane of the paper. What is the direction of the magnetic field in the region near points P, Q and R? What can you say about relative magnitude of magnetic fields at these points?

- (ii) A current carrying circular loop of area A

produces a magnetic field B at its centre. Show that the magnetic moment of the loop is $\frac{2BA}{\mu_0} \sqrt{\frac{A}{\pi}}$

OR

- (b) (i) Derive an expression for the torque acting on a rectangular current loop suspended in a uniform magnetic field.
- (ii) A charged particle is moving in a circular path with velocity \vec{V} in a uniform magnetic field \vec{B} . It is made to pass through a sheet of lead and as a consequence, it loses one half of its kinetic energy without change in its direction. How will (1) the radius of its path (2) its time period of revolution change?
33. (a) (i) (1) What are coherent sources? Why are they necessary for observing a sustained interference pattern?
(2) Lights from two independent sources are not coherent. Explain.
- (ii) Two slits 0.1 mm apart are arranged 1.20 m from a screen. Light of wavelength 600 nm from a distant source is incident on the slits.
(1) How far apart will adjacent bright interference fringes be on the screen?
(2) Find the angular width (in degree) of the first bright fringe.

OR

- (b) (i) Define a wave front. An incident plane wave falls on a convex lens and gets refracted through it. Draw a diagram to show the incident and refracted wave front.
- (ii) A beam of light coming from a distant source is refracted by a spherical glass ball (refractive index 1.5) of radius 15 cm. Draw the ray diagram and obtain the position of the final image formed.

Delhi Set-2

55/1/2

Note: Except these, all other questions have been given in Delhi Set-1

SECTION - A

1. In the figure curved lines represent equipotential surfaces. A charge Q is moved along different paths A, B, C and D. The work done on the charge will be maximum along the path

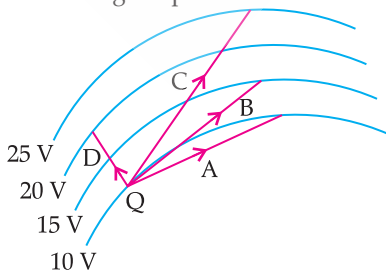

- (A) A (B) B
(C) C (D) D
2. The resistance of a wire of length L and radius r is R . Which one of the following would provide a wire of the same material of resistance $\frac{R}{2}$?

- (A) Using a wire of same radius and twice the length
(B) Using a wire of same radius and half length
(C) Using a wire of same length and twice the radius
(D) Using a wire of same length and half the radius
4. A circular coil of diameter 15 mm having 300 turns is placed in a magnetic field of 30 mT such that the plane of the coil is perpendicular to the direction of magnetic field. The magnetic field is reduced uniformly to zero in 20 ms and again increased uniformly to 30 mT in 40 ms. If the emfs induced in the two time intervals are e_1 and e_2 respectively, then the value of e_1/e_2 is
- (A) $\frac{1}{2}$ (B) 1
(C) 2 (D) 4
7. Which one of the following correctly represents the change in wave characteristics (all in vacuum) from microwaves to X-rays in electromagnetic spectrum?
- | Speed | Wavelength | Frequency |
|------------------|------------|--------------|
| (A) Remains same | Decreases | Remains same |

- (B) Remains same Decreases Increases
 (C) Increases Increases Decreases
 (D) Remains same Increases Remains same
8. The speed of light in two media '1' and '2' are v_1 and v_2 ($v_2 > v_1$) respectively. For a ray of light to undergo total internal reflection at the interface of these two media, it must be incident from
 (A) medium '1' and at an angle greater than $\sin^{-1}\left(\frac{v_1}{v_2}\right)$
 (B) medium '1' and at an angle greater than $\cos^{-1}\left(\frac{v_1}{v_2}\right)$
 (C) medium '2' and at an angle greater than $\sin^{-1}\left(\frac{v_1}{v_2}\right)$
 (D) medium '2' and at an angle greater than $\cos^{-1}\left(\frac{v_1}{v_2}\right)$
9. A source produces monochromatic light of frequency 5.0×10^{14} Hz and the power emitted is 3.31 mW. The number of photons emitted per second by the source, on an average is
 (A) 10^{16} (B) 10^{24}
 (C) 10^{10} (D) 10^{20}

SECTION – B

17. Show that $\vec{E} = \rho \vec{J}$ leads to Ohm's law. Write a

Delhi Set-3

55/1/3

Note: Except these, all other questions have been given in Delhi Set-1 & Set-2

SECTION – A

1. A charge Q is fixed in position. Another charge q is brought near charge Q and released from rest. Which of the following graphs is the correct representation of the acceleration of the charge q as a function of its distance r from charge Q ?

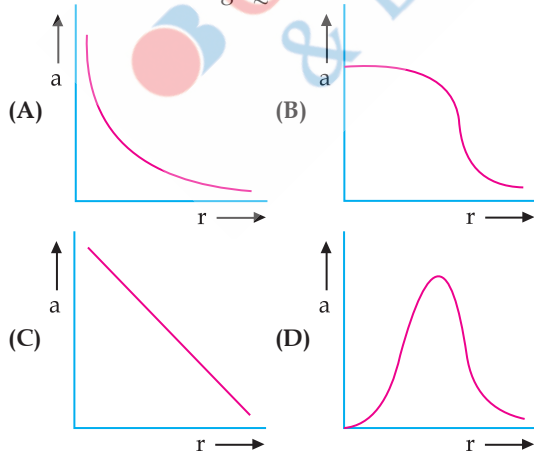

2. Two conductors A and B of the same material have their lengths in the ratio 1 : 2 and radii in the ratio 2 : 3. If they are connected in parallel across a battery, the ratio $\frac{v_A}{v_B}$ of the drift velocities of electrons in

condition in which the Ohm's law is not valid for a material.

19. A spherical convex surface of radius of curvature R separates glass (refractive index 1.5) from air. Light from a point source placed in air at distance $R/2$ from the surface falls on it. Find the position and nature of the image formed.
20. The energy of an electron in an orbit of Bohr hydrogen atom is -3.4 eV. Find its angular momentum.
23. (a) Define magnetic moment of a current-carrying coil. Write its SI unit.
 (b) A coil of 60 turns and area $1.5 \times 10^{-3} \text{ m}^2$ carrying 2 A current lies in a vertical plane. It experiences a torque of 0.12 Nm when placed in a uniform horizontal magnetic field. The torque acting on the coil changes to 0.05 Nm after the coil is rotated about its diameter by 90° , in the magnetic field. Find the magnitude of the magnetic field.
24. Consider two long co-axial solenoids S_1 and S_2 , each of length l ($\gg r_2$) and of radius r_1 and r_2 ($r_2 > r_1$). The number of turns per unit length are n_1 and n_2 respectively. Derive an expression for mutual inductance M_{12} of solenoid S_1 with respect to solenoid S_2 . Show that $M_{21} = M_{12}$.
26. (a) Draw a plot of frequency ν of incident radiations as a function of stopping potential V_0 for a given photo emissive material. What information can be obtained from the value of the intercept on the stopping potential axis?
 (b) Calculate : (i) the momentum and (ii) de Broglie wavelength, of an electron with kinetic energy of 80 eV.

them will be

- (A) 2 (B) $\frac{1}{2}$
 (C) $\frac{3}{2}$ (D) $\frac{8}{9}$
4. The ratio of the number of turns of the primary to the secondary coils in an ideal transformer is 20 : 1. If 240 V ac is applied from a source to the primary coil of transformer and a 6.0Ω resistor is connected across the output terminals, then current drawn by the transformer from the source will be
 (A) 4.0 A (B) 3.8 A
 (C) 0.97 A (D) 0.10 A
7. X-rays are more harmful to human beings than ultraviolet radiations because X-rays -
 (A) have frequency lower than that of ultraviolet radiations.
 (B) have wavelength smaller than that of ultraviolet radiations.
 (C) move faster than ultraviolet radiations in air.
 (D) are mechanical waves but ultraviolet radiations are electro-magnetic waves.
8. A point source is placed at the bottom of a tank containing a transparent liquid (refractive index n) to a depth H . The area of the surface of the liquid through which light from the source can emerge out is

- (A) $\frac{\pi H^2}{(n-1)}$ (B) $\frac{\pi H^2}{(n^2-1)}$
 (C) $\frac{\pi H^2}{\sqrt{n^2-1}}$ (D) $\frac{\pi H^2}{(n^2+1)}$

9. In a photoelectric experiment with a material of work function 2.1 eV, the stopping potential is found to be 2.5 V. The maximum kinetic energy of ejected photoelectrons is
 (A) 0.4 eV (B) 2.1 eV
 (C) 2.5 eV (D) 4.6 eV

SECTION - B

17. n identical cells, each of e.m.f. E and internal resistance r , are connected in series. Later on it was found out that two cells 'X' and 'Y' are connected in reverse polarities. Calculate the potential difference across the cell 'X'.
19. A double convex lens of glass has both faces of the same radius of curvature 17 cm. Find its focal length if it is immersed in water. The refractive indices of glass and water are 1.5 and 1.33 respectively.
20. An electron in Bohr model of hydrogen atom makes a transition from energy level -1.51 eV to -3.40 eV. Calculate the change in the radius of its orbit. The radius of orbit of electron in its ground state is 0.53 \AA .
23. A particle of charge q is moving with a velocity \vec{v} at a distance ' d ' from a long straight wire carrying a current ' I ' as shown in figure. At this instant, it is subjected to a uniform electric field \vec{E} such that the particle keeps moving undeviated. In terms of unit vectors \hat{i}, \hat{j} and \hat{k} find—

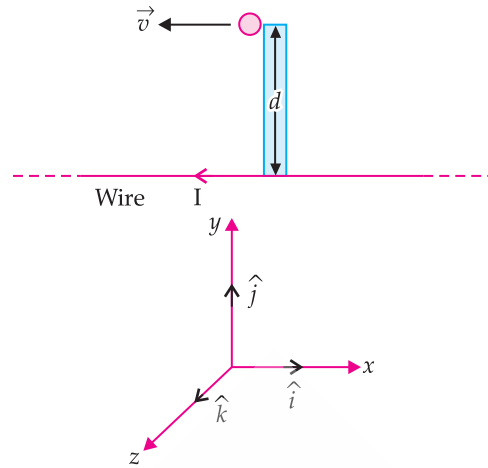

- (a) the magnetic field \vec{B}
 (b) the magnetic force \vec{F}_m and
 (c) the electric field \vec{E} acting on the charge.
24. An ac source of voltage $V = V_m \sin \omega t$ is connected to a series combination of LCR circuit. Draw the phasor diagram. Using it obtain an expression for the impedance of the circuit and the phase difference between applied voltage and the current.
26. (a) Mention any three features of results of experiment on photoelectric effect which cannot be explained using the wave theory of light.
 (b) In his experiment on photoelectric effect Robert A. Millikan found the slope of the cut-off voltage versus frequency of incident light plot to be $4.12 \times 10^{-15} \text{ Vs}$. Calculate the value of Planck's constant from it.

Outside Delhi Set-1

55/2/1

Note: Please follow the Since General Instructions as given in Delhi Set-1

SECTION A

1. Two charges $-q$ each are placed at the vertices A and B of an equilateral triangle ABC. If M is the midpoint of AB, the net electric field at C will point along
 (A) CA (B) CB
 (C) MC (D) CM
2. A student has three resistors, each of resistance R . To obtain a resistance of $\frac{2}{3} R$, she should connect
 (A) all the three resistors in series.
 (B) all the three resistors in parallel.
 (C) two resistors in series and then this combination in parallel with the third resistor.
 (D) two resistors in parallel and then this combination in series with the third resistor.
3. A 1 cm straight segment of a conductor carrying 1 A current in x direction lies symmetrically at origin of Cartesian coordinate system. The magnetic field due to this segment at point $(1\text{m}, 1\text{m}, 0)$ is
 (A) $1.0 \times 10^{-9} \hat{k} \text{ T}$ (B) $-1.0 \times 10^{-9} \hat{k} \text{ T}$
 (C) $\frac{5.0}{\sqrt{2}} \times 10^{-10} \hat{k} \text{ T}$ (D) $-\frac{5.0}{\sqrt{2}} \times 10^{-10} \hat{k} \text{ T}$

4. The magnetic field due to a small magnetic dipole of dipole moment ' M ' at a distance ' r ' from the centre along the axis of the dipole is given by

- (A) $\frac{\mu_0}{4\pi} \times \frac{2M}{r^3}$ (B) $\frac{\mu_0}{4\pi} \times \frac{M}{r^3}$
 (C) $\frac{\mu_0}{4\pi} \times \frac{M}{2r^3}$ (D) $\frac{\mu_0}{4\pi} \times \frac{2M}{r^2}$

5. In the figure X is a coil wound over a hollow wooden pipe.

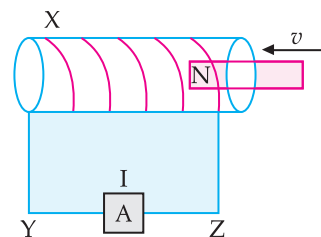

- A permanent magnet is pushed at a constant speed v from the right into the pipe and it comes out at the left end of the pipe. During the entry and the exit of the magnet, the current in the wire YZ will be from
 (A) Y to Z and then Y to Z
 (B) Z to Y and then Y to Z

- (C) Y to Z and then Z to Y
(D) Z to Y and then Z to Y

6. The alternating current I in an inductor is observed to vary with time t as shown in the graph for a cycle.

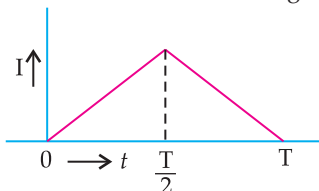

Which one of the following graphs is the correct representation of wave form of voltage V with time t ?

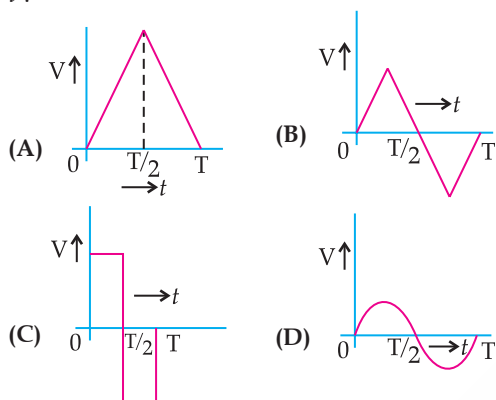

7. A transformer is connected to a 200 V ac source. The transformer supplies 3000 V to a device. If the number of turns in the primary coil is 450, then the number of turns in its secondary coil is
(A) 30 (B) 450
(C) 4500 (D) 6750
8. Which one of the following statements is correct? Electric field due to static charges is
(A) conservative and field lines do not form closed loops.
(B) conservative and field lines form closed loops.
(C) non-conservative and field lines do not form closed loops.
(D) non-conservative and field lines form closed loops.
9. A tub is filled with a transparent liquid to a height of 30.0 cm. The apparent depth of a coin lying at the bottom of the tub is found to be 16.0 cm. The speed of light in the liquid will be
(A) $1.6 \times 10^8 \text{ m s}^{-1}$ (B) $2.0 \times 10^8 \text{ m s}^{-1}$
(C) $3.0 \times 10^8 \text{ m s}^{-1}$ (D) $2.5 \times 10^8 \text{ m s}^{-1}$
10. Atomic spectral emission lines of hydrogen atom are incident on a zinc surface. The lines which can emit photoelectrons from the surface are members of
(A) Balmer series
(B) Paschen series
(C) Lyman series
(D) Neither Balmer nor Paschen nor Lyman series
11. The energy of an electron in a hydrogen atom in ground state is -13.6 eV . Its energy in an orbit corresponding to quantum number n is -0.544 eV . The value of n is
(A) 2 (B) 3
(C) 4 (D) 5

12. When the resistance measured between p and n ends of a p - n junction diode is high, it can act as a/an
(A) resistor (B) inductor
(C) capacitor (D) switch

For Questions 13 to 16, two statements are given—one labelled Assertion (A) and other labelled Reason (R). Select the correct answer to these questions from the codes (A), (B), (C) and (D) as given below :

- (A) If both Assertion (A) and Reason (R) are true and Reason (R) is the correct explanation of Assertion (A).
(B) If both Assertion (A) and Reason (R) are true but Reason (R) is not the correct explanation of Assertion (A).
(C) If Assertion (A) is true but Reason (R) is false.
(D) If both Assertion (A) and Reason (R) are false.
13. **Assertion (A):** In a semiconductor diode the thickness of depletion layer is not fixed.
Reason (R): Thickness of depletion layer in a semiconductor device depends upon many factors such as biasing of the semiconductor.
14. **Assertion (A):** In Bohr model of hydrogen atom, the angular momentum of an electron in n^{th} orbit is proportional to the square root of its orbit radius r_n .
Reason (R): According to Bohr model, electron can jump to its nearest orbits only.
15. **Assertion (A):** Out of infrared and radio waves, the radio waves show more diffraction effect.
Reason (R): Radio waves have greater frequency than infrared waves.
16. **Assertion (A):** In an ideal step-down transformer, the electrical energy is not lost.
Reason (R): In a step-down transformer, voltage decreases but the current increases.

SECTION-B

17. (a) Two wires of the same material and the same radius have their lengths in the ratio 2 : 3. They are connected in parallel to a battery which supplies a current of 15 A. Find the current through the wires.

OR

- (b) In the circuit, three ideal cells of e.m.f V , V and $2V$ are connected to a resistor of resistance R , a capacitor of capacitance C and another resistor of resistance $2R$ as shown in figure. In the steady state find (i) the potential difference between P and Q and (ii) potential difference across capacitor C.

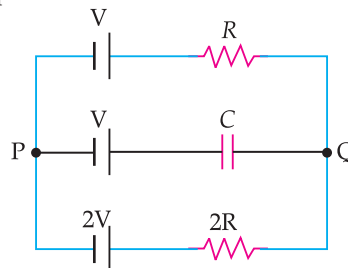

18. In a double-slit experiment, 6th dark fringe is observed at a certain point of the screen. A transparent sheet of thickness t and refractive index n is now introduced in the path of one of the two interfering waves to increase its phase by $27\pi (n - 1) \frac{t}{\lambda}$. The pattern is shifted and 8th bright fringe is observed at the same point. Find the relation for thickness t in terms of n and λ
19. Two concave lenses A and B, each of focal length 8.0 cm are arranged coaxially 16 cm apart as shown in figure. An object P is placed at a distance of 4.0 cm from A. Find the position and nature of the final image formed.

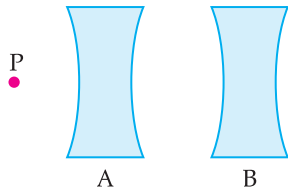

20. A light of wavelength 400 nm is incident on metal surface whose work function is 3.0×10^{-19} J. Calculate the speed of the fastest photoelectrons emitted.
21. The threshold voltage of a silicon diode is 0.7 V. It is operated at this point by connecting the diode in series with a battery of V volt and a resistor of 1000 Ω . Find the value of V when the current drawn is 15 mA.

SECTION – C

22. (a) A cell of e.m.f. E and internal resistance r is connected with a variable external resistance R and a voltmeter showing potential drop V across R . Obtain the relationship between V , E , R and r .
- (b) Draw the shape of the graph showing the variation of terminal voltage V of the cell as a function of current I drawn from it. How one can determine the e.m.f. of the cell and its internal resistance from this graph?
23. (a) In a region of a uniform electric field \vec{E} , a negatively charged particle is moving with a constant velocity $\vec{v} = -v_0 \hat{i}$ near a long straight conductor coinciding with XX' axis and carrying current I towards $-X$ axis. The particle remains at a distance d from the conductor.
- (i) Draw diagram showing direction of electric and magnetic fields.
- (ii) What are the various forces acting on the charged particle?
- (iii) Find the value of v_0 in terms of E , d and I .

OR

- (b) Two infinitely long conductors kept along XX' and YY' axes are carrying current I_1 and I_2 along $-X$ axis and $-Y$ axis respectively. Find the magnitude and direction of the net magnetic field produced at point $P(X, Y)$.
24. (a) State Lenz's law.
- (b) In the given figure.

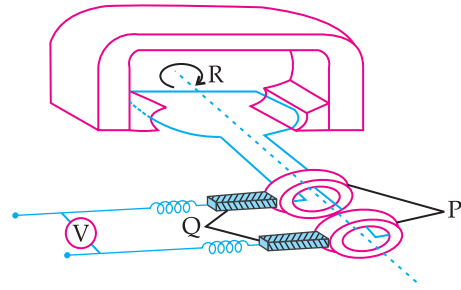

- (i) Identify the machine. .
- (ii) Name the parts P, Q and R of the machine.
- (iii) Give the polarities of the magnetic poles.
- (iv) Write the two ways of increasing the output voltage.
25. (a) The electric field \vec{E} of an electromagnetic wave propagating in north direction is oscillating in up and down direction. Describe the direction of magnetic field \vec{B} of the wave.
- (b) Are the wave length of radio waves and microwaves longer or shorter than those detectable by human eyes?
- (c) Write main use of each of the following in human life :
- (i) Infrared waves (ii) Gamma rays
26. (a) When a parallel beam of light enters water surface obliquely at some angle, what is the effect on the width of the beam?
- (b) With the help of a ray diagram, show that a straw appears bent when it is partly dipped in water and explain it.
- (c) Explain the transmission of optical signal through an optical fibre by a diagram.
27. (a) Show the variation of binding energy per nucleon with mass number. Write the significance of the binding energy curve.
- (b) Two nuclei with lower binding energy per nucleon form a nuclei with more binding energy per nucleon.
- (i) What type of nuclear reaction is it?
- (ii) Whether the total mass of nuclei increases, decreases or remains unchanged?
- (iii) Does the process require energy or produce energy?
28. (a) What are majority and minority charge carriers in an extrinsic semiconductor?
- (b) A $p-n$ junction is forward biased. Describe the movement of the charge carriers which produce current in it.
- (c) The graph shows the variation of current with voltage for a $p-n$ junction diode.

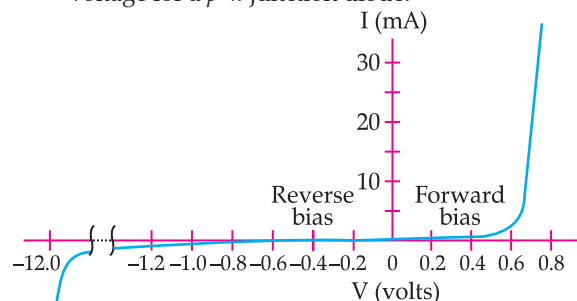

Estimate the dynamic resistance of diode at $V = -0.6$ volt.

SECTION -D

Question numbers 29 and 30 are case study based questions. Read the following paragraphs and answer the questions that follow.

29. A parallel plate capacitor has two parallel plates which are separated by an insulating medium like air, mica, etc. When the plates are connected to the terminals of a battery, they get equal and opposite charges and an electric field is set up in between them. This electric field between the two plates depends upon the potential difference applied, the separation of the plates and nature of the medium between the plates

- (i) The electric field between the plates of a parallel plate capacitor is E . Now the separation between the plates is doubled and simultaneously the applied potential difference between the plates is reduced to half of its initial value. The new value of the electric field between the plates will be

- (A) E (B) $2E$
(C) $\frac{E}{4}$ (D) $\frac{E}{2}$

- (ii) A constant electric field is to be maintained between the two plates of a capacitor whose separation d changes with time. Which of the graphs correctly depicts the potential difference (V) to be applied between the plates as a function of separation between the plates (d) to maintain the constant electric field?

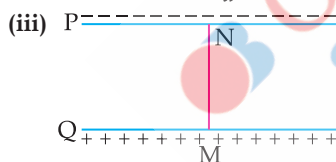
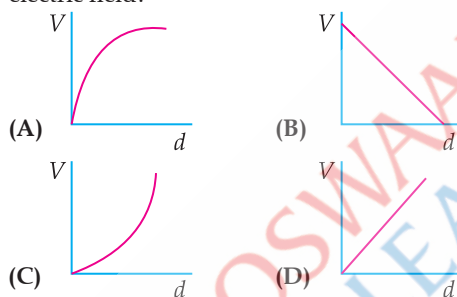

In the above figure P, Q are the two parallel plates of a capacitor. Plate Q is at positive potential with respect to plate P. MN is an imaginary line drawn perpendicular to the plates. Which of the graphs shows correctly the variations of the magnitude of electric field strength E along the line MN?

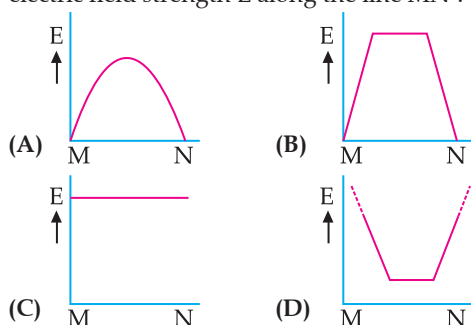

- (iv) Three parallel plates are placed above each other with equal displacement d between neighbouring plates. The electric field between the first pair of the plates is \vec{E}_1 and the electric field between the second part of the plates is \vec{E}_2 . The potential difference between the third and the first plate is:

- (A) $(\vec{E}_1 + \vec{E}_2) \cdot \vec{d}$ (B) $(\vec{E}_1 - \vec{E}_2) \cdot \vec{d}$
(C) $(\vec{E}_2 - \vec{E}_1) \cdot \vec{d}$ (D) $\frac{d(\vec{E}_1 + \vec{E}_2)}{2}$

OR

A material of dielectric constant K is filled in a parallel plate capacitor of capacitance C . The new value of its capacitance becomes

- (A) C (B) $\frac{C}{K}$
(C) CK (D) $C\left(1 + \frac{1}{K}\right)$

30. When a photon of suitable frequency is incident on a metal surface, photoelectron is emitted from it. If the frequency is below a threshold frequency (ν_0) for the surface, no photoelectron is emitted. For a photon of frequency ν ($\nu > \nu_0$), the kinetic energy of the emitted photoelectrons is $h(\nu - \nu_0)$. The photocurrent can be stopped by applying a potential V_0 called 'stopping potential' on the anode. Thus maximum kinetic energy of photoelectrons $K_m = eV_0 = h(\nu - \nu_0)$. The experimental graph between V_0 and ν for a metal is shown in figure. This is a straight line of slope m .

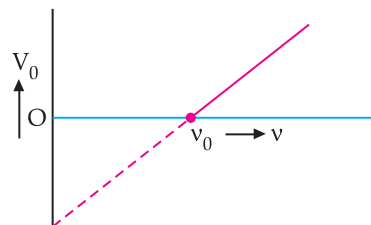

- (i) The straight line graphs obtained for two metals
(A) coincide each other.
(B) are parallel to each other.
(C) are not parallel to each other and cross at a point on ν -axis.
(D) are not parallel to each other and do not cross at a point on ν -axis.

- (ii) The value of Planck's constant for this metal is

- (A) $\frac{e}{m}$ (B) $\frac{1}{me}$
(C) me (D) $\frac{m}{e}$

- (iii) The intercepts on ν -axis and V_0 -axis of the graph are respectively:

- (A) $\nu_0, \frac{h\nu_0}{e}$ (B) $\nu_0, h\nu_0$
(C) $\frac{h\nu_0}{e}, \nu_0$ (D) $h\nu_0, \nu_0$

OR

When the wavelength of a photon is doubled, how many times its wave number and frequency become, respectively ?

- (A) $2, \frac{1}{2}$ (B) $\frac{1}{2}, \frac{1}{2}$
 (C) $\frac{1}{2}, 2$ (D) $2, 2$

(iv) The momentum of a photon is 5.0×10^{-29} kg. m/s. Ignoring relativistic effects (if any), the wavelength of the photon is

- (A) $1.33 \mu\text{m}$ (B) $3.3 \mu\text{m}$
 (C) $16.6 \mu\text{m}$ (D) $13.3 \mu\text{m}$

SECTION – E

31. (a) (i) A small conducting sphere A of radius r charged to a potential V , is enclosed by a spherical conducting shell B of radius R . If A and B are connected by a thin wire, calculate the final potential on sphere A and shell B.
 (ii) Write two characteristics of equipotential surfaces. A uniform electric field of 50 NC^{-1} is set up in a region along $+x$ axis. If the potential at the origin $(0, 0)$ is 220 V , find the potential at a point $(4\text{m}, 3\text{m})$.

OR

- (b) (i) What is difference between an open surface and a closed surface? Draw, elementary surface vector $d\vec{S}$ for a spherical surface S .
 (ii) Define electric flux through a surface. Give the significance of a Gaussian surface. A charge outside a Gaussian surface does not contribute to total electric flux through the surface. Why?
 (iii) A small spherical shell S_1 has point charges $q_1 = -3 \mu\text{C}$, $q_2 = -2 \mu\text{C}$ and $q_3 = 9 \mu\text{C}$ inside it. This shell is enclosed by another big spherical shell S_2 . A point charge Q is placed in between the two surfaces S_1 and S_2 . If the electric flux through the surface S_2 is four times the flux through surface S_1 find charge Q .
32. (a) (i) What is the source of force acting on a current-carrying conductor placed in a magnetic field? Obtain the expression for force acting between two long straight parallel conductors carrying steady currents and hence define 'ampere'.
 (ii) A point charge q is moving with velocity \vec{v} in a uniform magnetic field \vec{B} . Find the work done by the magnetic force on the charge.

(iii) Explain the necessary conditions in which the trajectory of a charged particle is helical in a uniform magnetic field.

OR

- (b) (i) A current carrying loop can be considered as a magnetic dipole placed along its axis. Explain.
 (ii) Obtain the relation for magnetic dipole moment \vec{M} of current carrying coil. Give the direction of \vec{M} .
 (iii) A current carrying coil is placed in an external uniform magnetic field. The coil is free to turn in the magnetic field. What is the net force acting on the coil? Obtain the orientation of the coil in stable equilibrium. Show that in this orientation the flux of the total field (field produced by the loop + external field) through the coil is maximum.
33. (a) (i) A thin pencil of length $(f/4)$ is placed coinciding with the principal axis of a mirror of focal length f . The image of the pencil is real and enlarged, just touches the pencil. Calculate the magnification produced by the mirror.
 (ii) A ray of light is incident on a refracting face AB of a prism ABC at an angle of 45° . The ray emerges from face AC and the angle of deviation is 15° . The angle of prism is 30° . Show that the emergent ray is normal to the face AC from which it emerges out. Find the refraction index of the material of the prism.

OR

- (b) (i) Light consisting of two wavelengths 600 nm and 480 nm is used to obtain interference fringes in a double slit experiment. The screen is placed 1.0 m away from slits which are 1.0 mm apart.
 (1) Calculate the distance of the third bright fringe on the screen from the central maximum for wavelength 600 nm .
 (2) Find the least distance from the central maximum where the bright fringes due to both the wavelengths coincide.
 (ii) (1) Draw the variation of intensity with angle of diffraction in single slit diffraction pattern. Write the expression for value of angle corresponding to zero intensity locations.
 (2) In what way diffraction of light waves differs from diffraction of sound waves?

Outside Delhi Set-2

55/2/2

Note: Except these, all other questions have been given in Outside Delhi Set-1

SECTION – A

1. Two identical point charges are placed at the two vertices A and B of an equilateral triangle of side l . The magnitude of the electric field at the third vertex P is E . If a hollow conducting sphere of radius $(l/4)$ is placed at P , the magnitude of the electric field at point P now becomes
 (A) $>E$ (B) E
 (C) $\frac{E}{2}$ (D) zero

2. A battery of e.m.f. 12 V and internal resistance 0.5Ω is connected to a 9.5Ω resistor through a key. The ratio of potential difference between the two terminals of the battery, when the key is open to that when the key is closed, is
 (A) 1.05 (B) 1
 (C) 0.95 (D) 1.1
4. A diamagnetic substance is brought, one by one, near the north pole and the south pole of a bar magnet. It is

- (A) repelled by north pole and attracted by south pole.
 (B) attracted by north pole and repelled by south pole.
 (C) attracted by north pole as well as by south pole.
 (D) repelled by north pole as well as by south pole.
5. Two long solenoids of radii r_1 and $r_2 (> r_1)$ and number of turns per unit length n_1 and n_2 respectively are co-axially wrapped one over the other. The ratio of self-inductance of inner solenoid to their mutual inductance is-

- (A) $\frac{n_1}{n_2}$ (B) $\frac{n_2}{n_1}$
 (C) $\frac{n_1 r_1^2}{n_2 r_2^2}$ (D) $\frac{n_2 r_1^2}{n_1 r_2^2}$

7. A coil of an ac generator, having 100 turns and area 0.1 m^2 each, rotates at half a rotation per second in a magnetic field of 0.02 T . The maximum emf generated in the coil is

- (A) 0.31 V (B) 0.20 V
 (C) 0.63 V (D) 0.10 V

9. The focal length of a concave mirror in air is f . When the mirror is immersed in a liquid of refractive index $\frac{5}{3}$ its focal length will become

- (A) $\frac{5}{3} f$ (B) $\frac{3}{5} f$
 (C) $\frac{2}{3} f$ (D) f

SECTION – B

18. Show the refraction of light wave at a plane interface using Huygens' principle and prove Snell's law.

19. Two convex lenses A and B, each of focal length 10.0 cm , are mounted on an optical bench at 50.0 cm and 70.0 cm respectively. An object is mounted at 20.0 cm . Find the nature and position of the final image formed by the combination.
20. Radiations of two frequencies are incident on a metal surface of work function 2.0 eV one by one. The energies of their photons are 2.5 eV and 4.5 eV respectively. Find the ratio of the maximum speed of the electrons emitted in the two cases.

SECTION – C

22. (a) Define resistivity of a conductor. Discuss its dependence on temperature of the conductor and draw a plot of resistivity of copper as a function of temperature.
 (b) (i) "A low voltage battery from which high current is required must have low internal resistance." Justify.
 (ii) "A high voltage battery must have a large internal resistance." Justify.
24. Differentiate between the peak value and root mean square value of an alternating current. Derive the expression for the root mean square value of alternating current, in terms of its peak value.
25. (a) How is an electromagnetic wave produced?
 (b) An electromagnetic wave is travelling in vertically upward direction. At an instant, its electric field vector points in west direction. In which direction does the magnetic field vector point at that instant?
 (c) Estimate the ratio of shortest wave length of radio waves to the longest wave length of gamma waves.

Outside Delhi Set-3

55/2/3

Note: Except these, all other questions have been given in Outside Delhi Set-1 & Set-2

SECTION – A

1. Consider two identical dipoles D_1 and D_2 . Charges $-q$ and q of dipole D_1 are located at $(0, 0)$ and $(a, 0)$ and that of dipole D_2 at $(0, a)$ and $(0, 2a)$ in x - y plane, respectively. The net dipole moment of the system is
- (A) $qa(\hat{i} + \hat{j})$ (B) $-qa(\hat{i} + \hat{j})$
 (C) $qa(\hat{i} - \hat{j})$ (D) $-qa(\hat{i} - \hat{j})$
2. Which pair of readings of ideal voltmeter and ideal ammeter in the given circuit is possible when a suitable power source of 3Ω internal resistance is connected between P and Q ?

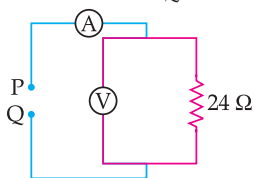

- (A) $12.0 \text{ V}, 2.0 \text{ A}$ (B) $2.0 \text{ V}, 0.5 \text{ A}$
 (C) $6.0 \text{ V}, 2.0 \text{ A}$ (D) $12 \text{ V}, 0.5 \text{ A}$

4. A material is pushed out when placed in a uniform

magnetic field. The material is

- (A) non-magnetic (B) diamagnetic
 (C) paramagnetic (D) ferromagnetic
5. A soft iron rod X is allowed to fall on the two poles of a U shaped permanent magnet as shown in figure. A coil is wrapped over one arm of the U shaped magnet.

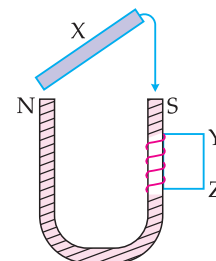

During fall of the rod, the current in the coil will be

(A) clockwise current (B) anti-clockwise current
 (C) alternating current (D) zero

7. The number of turns between different pairs of output terminals are shown for a step-up transformer.

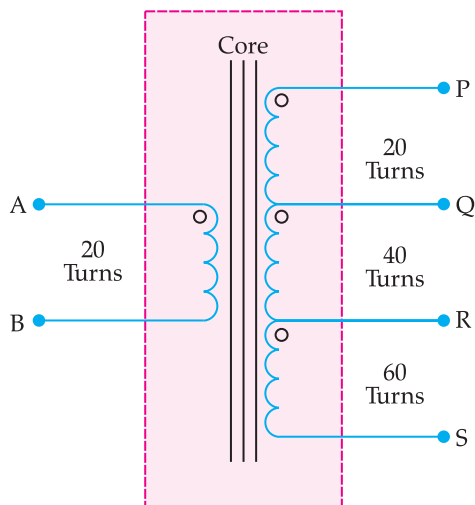

Input voltage of 20 V is applied between A and B. Between which two terminals will the output be 120 V?

- (A) P and Q (B) Q and S
 (C) P and R (D) P and S
9. The plane face of a planoconvex lens is silvered. The refractive index of material and radius of curvature of the curved surface of the lens are n and R respectively. This lens will behave as a concave mirror of focal length
- (A) $\frac{R}{n}$ (B) $\frac{R}{(n-1)}$
 (C) nR (D) $\frac{R}{2(n-1)}$

SECTION – B

18. In a double slit experiment, it is observed that the angular width of one fringe formed on the screen is

0.2° . The wavelength of light used in the experiment is 500 nm. Calculate the separation of the two slits.

19. A light beam converges at a point O. In the path of this beam, a concave lens of focal length 15 cm is placed at a distance of 10 cm before point O. The beam now converges at a point O'. Find the magnitude and the direction of shift OO'.
20. The threshold wavelength of a metal is 450 nm. Calculate (i) the work function of the metal in eV and (ii) the maximum energy of the ejected photoelectrons in eV by incident radiation of 250 nm.

SECTION – C

22. (a) Define Electrical conductivity. Obtain the expression of electrical conductivity of a conductor in terms of number density and relaxation time of free electrons.
 (b) Explain qualitative change in resistivity of a conductor with temperature using expression obtained in (a)
24. (a) AC voltage of frequency ω is applied across a series LCR circuit. Draw the phasor diagram and obtain the impedance of the circuit.
 (b) Discuss 'resonance' in a series LCR circuit and write the expression for resonant frequency.
25. (a) The amplitude of a light wave becomes n times. This results in intensity of the wave becoming m times. What is the relation between n and m ?
 (b) White light is incident on three identical surfaces—a black surface, a yellow surface and a white surface, one by one. For which surface, the pressure exerted on the surface by the incident light will be (i) maximum (ii) minimum? Justify your answer.



ANSWERS

Delhi Set-1

55/1/1

SECTION – A

1. Option (A) is correct.

Explanation: F

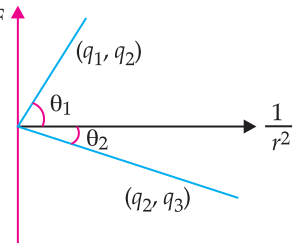

Given, q_2 is positive and least in magnitude.

From Coulomb's Force, $F = \frac{1}{4\pi\epsilon_0} \frac{q_1 q_2}{r^2}$

Now, from the given graph F vs $1/r^2$, the product of the magnitude of the charges will be the slope of the curve.

$\therefore \tan\theta_1 > \tan\theta_2$

$\Rightarrow \theta_1 > \theta_2$

[if the given angle is very small]

$q_1 q_2 > q_2 q_3$

$\Rightarrow q_1 > q_3$

and q_2 has least magnitude.

Hence, $q_1 > q_3 > q_2$

2. Option (C) is correct.

Explanation: Given that wires P and Q are made of the same material, they have the same resistivity (ρ).

The resistance of a wire is given by the formula:

$$R = \rho \frac{L}{A}$$

Here, all alphabets are used in their usual meanings for **wire P**:

Its length be L , diameter be d ,

so its radius $r = \frac{d}{2}$

The cross-sectional area is: $A_p = \pi r^2 = \pi \left(\frac{d}{2}\right)^2 = \frac{\pi d^2}{4}$

The resistance of wire P is given as R , so:

$$R = \rho \frac{L}{A_p} = \rho \frac{L}{\frac{\pi d^2}{4}} = \rho \frac{4L}{\pi d^2}$$

For **wire Q**:

Its length is **half** of wire P, so $L_Q = \frac{L}{2}$, diameter is

twice that of wire P, so $d_Q = 2d$, and its radius is

$$r_Q = \frac{2d}{2} = d$$

The cross-sectional area:

$$A_Q = \pi r_Q^2 = \pi d^2$$

The resistance of **wire Q**:

$$R_Q = \rho \frac{L_Q}{A_Q} = \rho \frac{\frac{L}{2}}{\pi d^2} = \rho \frac{L}{2\pi d^2}$$

Now, dividing R_Q by R :

$$\frac{R_Q}{R} = \frac{\frac{\rho L}{2\pi d^2}}{\frac{4\rho L}{\pi d^2}} = \frac{1}{2} \times \frac{1}{4} = \frac{1}{8}$$

$$R_Q = \frac{R}{8}$$

3. Option (B) is correct.

Explanation: $I = 0.5$ A, $l = 1$ \hat{i} cm = 10^{-2} \hat{i} m,

$$\vec{B} = (0.4 \text{ mT})\hat{j} + (0.6 \text{ mT})\hat{k}$$

$$\vec{F} = I(\vec{l} \times \vec{B})$$

$$\vec{F} = 0.5 \times 10^{-3} \begin{vmatrix} \hat{i} & \hat{j} & \hat{k} \\ 10^{-2} & 0 & 0 \\ 0 & 0.4 & 0.6 \end{vmatrix}$$

$$\vec{F} = 0.5 \times 10^{-3} [-(0.6 \times 10^{-2})\hat{j} + (0.4 \times 10^{-2})\hat{k}]$$

$$\vec{F} = 0.5(-6\hat{j} + 4\hat{k}) \mu\text{N}$$

$$\vec{F} = (-3\hat{j} + 2\hat{k}) \mu\text{N}$$

4. Option (B) is correct.

Explanation: Given:

- Number of turns, $N = 100$
- Area of each turn, $A = 0.05$ m²
- Total resistance, $R = 1.5$ Ω
- Magnetic field, $B = 90$ mT = 90×10^{-3} T
- Initial flux, $\phi_{Bi} = BA = (90 \times 10^{-3}) \times (0.05) = 4.5 \times 10^{-3}$ Wb
- Final flux, $\phi_{Bf} = 0$ Wb
- Change in flux, $\Delta\phi_B = \phi_{Bf} - \phi_{Bi} = -4.5 \times 10^{-3}$ Wb

Using Faraday's Law:

$$e = -N \frac{\Delta\phi_B}{\Delta t}$$

Total charge induced:

$$Q = I\Delta t = \frac{\epsilon\Delta t}{R} = -N \frac{\Delta\phi_B}{R}$$

Substituting values:

$$Q = \frac{(100) \times (-4.5 \times 10^{-3})}{1.5}$$

$$Q = \frac{-0.45}{1.5} = -0.3$$
 C

Final answer : 0.3 C

5. (Bonus)

Explanation: $L = 0.016$ H

$$l = 0.81$$
 m

$$r = 0.02$$
 m

Formula: $L = \frac{\mu_0 N^2 A}{l}$

$$0.016 = \frac{4\pi \times 10^{-7} \times N^2 \times \pi \times 0.02^2}{0.81}$$

$$N = 9059$$

NOTE: Since, no options are matching with final answer, hence b 'Bonus' will given.

6. Option (D) is correct.

Explanation: $v = v_0 \sin \omega t$ and $i = i_0 \sin(\omega t + \phi)$

Average power over a full cycle is

$$\begin{aligned} P_{av} &= v_{rms} i_{rms} \cos \phi \\ &= \frac{v_0}{\sqrt{2}} \frac{i_0}{\sqrt{2}} \cos \phi \end{aligned}$$

$$\therefore P_{av} = \frac{v_0 i_0}{2} \cos \phi$$

7. Option (B) is correct.

Explanation: Formula: $E = \frac{hc}{\lambda}$

Energy and wavelength are inversely proportional.
wavelength of microwave > wavelength of UV > wavelength of X-rays

Hence,

$$P = \text{X-rays}$$

$$R = \text{UV}$$

$$Q = \text{Microwave}$$

8. Option (B) is correct.

Explanation: Given :

$$\text{Refractive index of water, } n = \frac{4}{3}$$

Actual depth of the coin, H

Apparent depth, h ,

Formula for Refractive index :

$$\text{Refraction Index} = \frac{\text{Real depth}}{\text{Apparent depth}}$$

$$n = \frac{H}{h}$$

$$\text{Rearrange, } h = \frac{H}{n}$$

$$\text{Putting values, } h = \frac{H}{\frac{4}{3}}$$

$$h = H \times \frac{3}{4} = \frac{3H}{4}$$

9. Option (C) is correct.

Explanation: From Einstein's equation, $h\nu = h\nu_0 + eV_0$

$$\Rightarrow \frac{h}{e} \nu - \frac{h}{e} \nu_0 = eV_0$$

Comparing the equation with $y = mx + c$; where m is the slope of the straight line obtained.

$$\therefore m = \frac{h}{e} \Rightarrow e = \frac{h}{m}$$

10. Option (B) is correct.

Explanation: $\lambda = \frac{h}{mv}$; Since, speed is same for an electron, a proton and a deuteron,

$$\lambda \propto \frac{1}{m}$$

$$\therefore m_e < m_p < m_d$$

$$\therefore \lambda_e > \lambda_p > \lambda_d$$

11. Option (A) is correct.

Explanation: The curve of binding energy per nucleon as a function of mass number shows a peak around iron (Fe, mass number 56). This is because the binding energy per nucleon increases with mass number up to iron and then decreases for heavier elements.

12. Option (C) is correct.

Explanation: When a $p-n$ junction diode is forward biased, the barrier height decreases as the external voltage opposes the built-in potential. This results in a decrease in the depletion region width, allowing current to flow more easily through the junction.

13. Option (A) is correct.

Explanation: The assertion (A) is true because moving a magnet into a coil with a large number of turns will induce an opposing current that resists the motion of the magnet. This is in accordance with Lenz's law, which states that the induced current always opposes the change causing it.

14. Option (A) is correct.

Explanation: Assertion (A) is true: The deflection θ in a galvanometer is directly proportional to the current I passing through it.

$$\theta \propto I$$

This is because the torque acting on the coil is proportional to the current.

Reason (R) is true:

The coil of a galvanometer is suspended in a uniform radial magnetic field, ensuring that the torque is always proportional to the sine of the angle between the plane of the coil and the field. However, due to the radial nature of the field, the sine term remains constant, making the torque directly proportional to the current.

Reason (R) correctly explains Assertion (A):

The uniform radial magnetic field ensures that the deflection is linearly dependent on the current, which is why the deflection follows the relation $\theta \propto I$.

15. Option (C) is correct.

Explanation: To form a $p-n$ junction, we don't need to join a p -type semiconductor and an n -type semiconductor physically. Assertion (A) is correct. However, the Reason (R) incorrectly states that the carrier concentrations are in the reverse order. In a p -type semiconductor, $\eta_h \gg \eta_e$ because holes dominate, and in an n -type semiconductor, $\eta_e \gg \eta_h$, where electrons dominate. Therefore, Reason (R) is false.

16. Option (D) is correct.

Explanation: The potential energy (U) of an electron in a hydrogen atom is given by:

$$U = -\frac{ke^2}{r}$$

Since, U is negative, **Assertion (A) is false** because it incorrectly states that the potential energy is positive.

Total Energy of a Charged Particle

The total energy (E) of an electron in a hydrogen atom is given by: $E = -\frac{ke^2}{2r}$

The total energy is also negative, meaning that the electron is bound to the nucleus. The Reason (R) is false because it incorrectly states that the total energy of a charged particle is always positive. In bound systems like the hydrogen atom, the total energy is negative.

SECTION - B

17. When a current of 2 A is drawn from the battery, the potential difference across the rheostat is 5 V.

$$\therefore 5 = E - 2r \quad \dots(i)$$

When a current of 4A is drawn from the battery, the potential difference across the rheostat is 4 V.

$$\therefore 4 = E - 4r \quad \dots(ii)$$

Subtracting Eq. (i) from (ii);

$$r = \frac{1}{2} \text{ ohm}$$

Putting the value of r in Eq. (i)

$$5 = E - 2 \times \frac{1}{2}$$

$$E = 6V$$

18. (a) $\lambda = 600 \text{ nm}$

Formula: $d \sin \theta = n\lambda$, where d is the slit width.

For first minima in diffraction due to single slit:

$$d \sin \theta = \lambda. (n = 1)$$

Given, $\theta = 30^\circ$

$$d = \frac{\lambda}{\sin \theta} = \frac{600 \times 10^{-9}}{\sin 30^\circ}$$

$$= 1.2 \times 10^{-6} \text{ m}$$

$$d = 1.2 \mu\text{m}$$

OR

- (b) Given Data:

• Intensity of each wave, I_0

• Path difference, $\Delta x = \frac{\lambda}{8}$

Formula Used:

The resultant intensity in an interference pattern is given by:

$$I = I_1 + I_2 + \sqrt{2I_1I_2} \cos \phi$$

Since, both waves have equal intensity, $I_1 = I_2 = I_0$, the equation simplifies to:

$$I = I_0(2 + \sqrt{2})$$

where the **phase difference** ϕ is related to the path difference by:

$$\phi = \frac{2\pi}{\lambda} \times \Delta x$$

Substituting $\Delta x = \frac{\lambda}{8}$

$$\phi = \frac{2\pi}{\lambda} \times \frac{\lambda}{8} = \frac{2\pi}{8} = \frac{\pi}{4}$$

Then, $I = 2I_0 \left(1 + \cos \frac{\pi}{4} \right)$

$$I = 2I_0 \left(1 + \frac{\sqrt{2}}{2} \right)$$

$$I = I_0(2 + \sqrt{2})$$

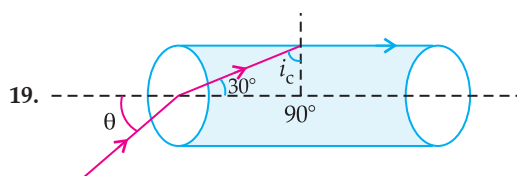

19.

Using TIR formula:

$$\sin i_c = \frac{1}{\mu_{\text{cylinder}}}$$

$$\sin i_c = \frac{\sqrt{3}}{2} = \sin 60^\circ$$

$$\Rightarrow i_c = 60^\circ$$

Using Snell's law of refraction,

$$\frac{\sin \theta}{\sin 30^\circ} = \frac{2}{\sqrt{3}}$$

$$\sin \theta = \frac{2}{\sqrt{3}} \times \frac{1}{2}$$

$$\theta = \sin^{-1} \left(\frac{1}{\sqrt{3}} \right)$$

20. Using Bohr's theory

Centripetal force = Electrostatic force

$$\frac{mv^2}{r} = \frac{kZe^2}{r^2}$$

$$\Rightarrow r = \frac{kZe^2}{mv^2} \quad \dots(i)$$

Angular momentum is quantised, i.e.,

$$mvr = \frac{nh}{2\pi}$$

$$\Rightarrow r = \frac{nh}{2\pi mv} \quad \dots(ii)$$

Equating (i) and (ii)

$$\frac{nh}{2\pi mv} = \frac{kZe^2}{mv^2}$$

$$v = \frac{2\pi kZe^2}{nh} \quad \dots(iii)$$

Putting Eq. (iii) in (ii)

$$r = \frac{n^2 h^2}{2\pi m \times 2\pi kZe^2}$$

$$r = \frac{n^2 h^2}{4\pi^2 m kZe^2} \quad \dots(iv)$$

$$\omega = \frac{v}{r}$$

$$T = \frac{2\pi}{\omega} = \frac{2\pi r}{v} = \frac{n^3 h^3}{4\pi^2 m k^2 Z^2 e^4}$$

(Putting the values of v and r from (iii) and (iv))

21. Number density of atoms in Si

$$= 5 \times 10^{28} \text{ atoms m}^{-3}$$

$$= 5 \times 10^{22} \text{ atoms cm}^{-3}$$

Since, 1 atom of dopant is doped in 5×10^7 silicon atoms,

$$\begin{aligned} \therefore \text{Total number of dopant atoms} \\ = \frac{5 \times 10^{22}}{5 \times 10^7} = 1 \times 10^{15} \text{ atoms cm}^{-3} \end{aligned}$$

Since, each dopant atom creates a hole in a p-type semiconductor, the number of holes created per cubic centimetre is $= 1 \times 10^{15}$

One example of such a dopant is boron (B), which is commonly used to create p-type semiconductors.

SECTION – C

22. (a) (i) Given Data:

Battery 1:

$$\text{EMF: } E_1 = 3 \text{ V}$$

$$\text{Internal resistance: } r_1 = 0.2 \Omega$$

Battery 2:

$$\text{EMF: } E_2 = 6 \text{ V}$$

$$\text{Internal resistance: } r_2 = 0.4 \Omega$$

$$\text{External resistor: } R = 4 \Omega$$

$$E_{eq} = \frac{E_1 r_2 + E_2 r_1}{r_1 + r_2}$$

$$E_{eq} = \frac{3 \times 0.4 + 6 \times 0.2}{0.4 + 0.2} = \frac{1.2 + 1.2}{0.6}$$

$$= \frac{2.4}{0.6} = 4 \text{ V}$$

$$(ii) \quad r_{eq} = \frac{r_1 r_2}{r_1 + r_2} = \frac{0.4 \times 0.2}{0.4 + 0.2} = \frac{0.08}{0.60}$$

$$= \frac{2}{15} \Omega = 0.133 \Omega$$

$$(iii) \quad I = \frac{E_{eq}}{r_{eq} + R} = \frac{4}{0.133 + 4}$$

$$= 0.968 \text{ A}$$

OR

(b) (i) A conductor of length l is connected across an ideal cell of emf E . Keeping the cell connected, the length of the conductor is increased to $2l$ by gradually stretching it. Hence, the volume of the conductor remains the same.

$$Al = A'l'$$

$$\text{Since, } l' = 2l$$

$$A' = \frac{A}{2}$$

$$R = \rho \frac{l}{A}$$

$$R' = \rho \frac{l'}{A'} = \rho \frac{2l}{\frac{A}{2}} = 4R$$

$$(2) \quad v_d = \frac{eE\tau}{m}$$

$$\frac{v'_d}{v_d} = \frac{E'}{E} = \frac{\frac{2l}{V}}{\frac{l}{V}} = \frac{l}{2l} = \frac{1}{2}$$

(ii) No, it does not mean that all the free electrons move in the same direction. In a conductor, free electrons are always in continuous motion due to thermal energy, moving randomly in different directions. However, when an electric field is applied, these electrons experience a net drift in the direction opposite to the field, moving from lower to higher potential. This drift occurs while the electrons continue their random motion, resulting in an overall movement influenced by both thermal motion and the applied electric field.

23. Let us consider a circular loop of radius a with centre C. Let the plane of the coil be perpendicular to plane of the paper and current I be flowing in the direction shown. Suppose P is any point on the axis a distance r from the centre.

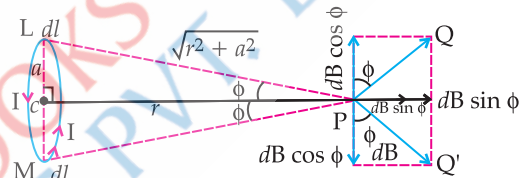

Let us consider a current element dl on top (L) where, current comes out of paper normally whereas at bottom (M) enters into the plane paper normally.

$$LP \perp dl$$

$$MP \perp dl$$

$$LP = MP = \sqrt{r^2 + a^2}$$

Now, magnetic field at P due to current element at L according to Biot-Savart Law,

$$dB = \frac{\mu_0}{4\pi} \frac{Idl \sin 90^\circ}{(r^2 + a^2)}$$

where,

a = radius of circular loop

r = distance of point P from centre along the axis.

$dB \cos \phi$ components balance each other and net magnetic field is given by

$$B = \int dB \sin \phi$$

$$= \int \frac{\mu_0}{4\pi} \left[\frac{Idl}{r^2 + a^2} \right] \cdot \frac{a}{\sqrt{r^2 + a^2}}$$

$$\left[\because \text{In } \triangle PCM \sin \phi = \frac{a}{\sqrt{r^2 + a^2}} \right]$$

$$= \frac{\mu_0}{4\pi} \frac{Ia}{(r^2 + a^2)^2} \int dl$$

$$= \frac{\mu_0}{4\pi} \frac{Ia}{(r^2 + a^2)^{3/2}} \times 2\pi a$$

$$B = \frac{\mu_0 I a^2}{2(r^2 + a^2)^{3/2}}$$

As the direction of the field is along +ve X-direction, we can write

$$\vec{B} = \frac{\mu_0 I a^2}{2(r^2 + a^2)^{3/2}} \hat{i}$$

At its centre, $r = 0$

$$B = \frac{\mu_0 I a^2}{2(a^2)^{3/2}} = \frac{\mu_0 I}{2a}$$

24. (a) The work done against back/induced emf is stored as magnetic potential energy.

The rate of work done, when a current i is passing through the coil, is

$$\frac{dW}{dt} = |\varepsilon|I = \left(L \frac{dI}{dt} \right) I$$

$$\begin{aligned} \therefore W &= \int dW = \int_0^I LIdI \\ &= \frac{1}{2} LI^2 \end{aligned}$$

- (b) Let the permittivity, permeability of free space, electric field, velocity of light are ε_0 , μ_0 , E , c respectively. The permittivity is given as:

$$\varepsilon_0 = \frac{1}{c^2 \mu_0}$$

The electric field is given as: $E = Bc$

The energy stored in a capacitor per unit volume is:

$$\frac{U}{Al} = \frac{1}{2} \varepsilon_0 E^2$$

$$U = \frac{1}{2} \times \frac{1}{c^2 \mu_0} \times (Bc)^2 \times Al$$

The magnetic energy density $u = \frac{U}{Al} = \frac{B^2}{2\mu_0}$

25. (a) Electric field between the capacitor plates is given by

$$E = \frac{\sigma}{\varepsilon_0} = \frac{q}{\varepsilon_0 A}$$

where q is the charge accumulated on the positive plate.

The electric flux through this plate is

$$\phi_E = EA = \frac{q}{\varepsilon_0 A} \cdot A = \frac{q}{\varepsilon_0}$$

\therefore Displacement current,

$$I_D = \varepsilon_0 \frac{d\phi}{dt} = \varepsilon_0 \frac{d}{dt} \left[\frac{q}{\varepsilon_0} \right] = \frac{dq}{dt}$$

But $\frac{dq}{dt}$ = the rate at which charge flows to positive plate through the conducting wire.

Hence $I_D = I_C$

i.e., Displacement current between capacitor plates = Conduction current in connecting wires.

- (b) Yes, Kirchhoff's first rule (junction rule) is valid at each plate of the capacitor. According to the

junction rule, the sum of currents entering any junction must be equal to the sum of currents leaving the junction.

In the case of a capacitor, the conduction current and the displacement current must be balanced. This ensures that the total current entering the capacitor is equal to the total current leaving it, maintaining the continuity of current in the circuit.

26. (a) The kinetic energy of emitted photoelectrons varies because different electrons in the metal have different initial energies before being ejected. According to Einstein's photoelectric equation:

$$K_{max} = h\nu - \phi$$

where:

- $h\nu$ is the energy of the incident photon,
- ϕ is the work function (minimum energy required to eject an electron),
- K_{max} is the maximum kinetic energy of the emitted photoelectron.

Electrons deeper inside the metal require more energy to escape than those near the surface, leading to a distribution of kinetic energies among the emitted photoelectrons.

- (b) Saturation current refers to the maximum photoelectric current when all emitted photoelectrons are collected by the anode. Since, the intensity of light is directly proportional to the number of incident photons, a higher intensity means more photons striking the metal surface per second.

As each photon ejects at most one electron, an increase in intensity leads to a higher number of emitted electrons, resulting in an increased saturation current. However, the kinetic energy of individual electrons remains unaffected by intensity.

- (c) The photoelectric effect occurs only if the energy of the incident photons is at least equal to the metal's work function (ϕ). The energy of a photon is given by:

$$E = \frac{hc}{\lambda}$$

As the wavelength (λ) increases, the photon energy decreases. When the wavelength reaches a threshold value (λ_{th}), corresponding to the work function:

$$\lambda_{th} = \frac{hc}{\phi}$$

the photon energy becomes insufficient to eject electrons, and photoemission ceases. Beyond this threshold wavelength, no electrons are emitted, regardless of the intensity of light.

27. (a) **Mass defect:** The mass defect of a nucleus is the difference between the mass of the completely assembled nucleus and the sum of the masses of the individual protons and neutrons that make it up.

$$\Delta m = (Zm_p + Nm_n) - M_{nucleus}$$

where:

Z = number of protons,

N = number of neutrons,

m_p = mass of a proton,
 m_n = mass of a neutron,

M_{nucleus} = actual mass of the nucleus.

This difference in mass is converted into binding energy according to Einstein's equation. $E = mc^2$.

Binding energy: The binding energy of a nucleus is the energy required to separate a nucleus into its individual protons and neutrons. It is related to the mass defect and provides a measure of the stability of the nucleus.

Fission process: Fission is the process in which a heavy nucleus splits into two lighter nuclei, releasing a significant amount of energy. The binding energy per nucleon increases as the nucleus splits, and this release of energy is due to the difference in binding energy between the fission products and the original nucleus.

- (b) The mass defect Δm is the difference between the total mass of the individual nucleons and the mass of the deuteron:

$$\begin{aligned}\Delta m &= (m_p + m_n) - m_{\text{deuteron}} \\ \Delta m &= (1.007277 + 1.008665) - 2.013553 \\ \Delta m &= 0.002389 \text{ u} \\ E &= \Delta mc^2 \\ E &= 0.002389 \times 931.5 \text{ MeV}/c^2 \\ E &= 2.225 \text{ MeV}\end{aligned}$$

28. (a)

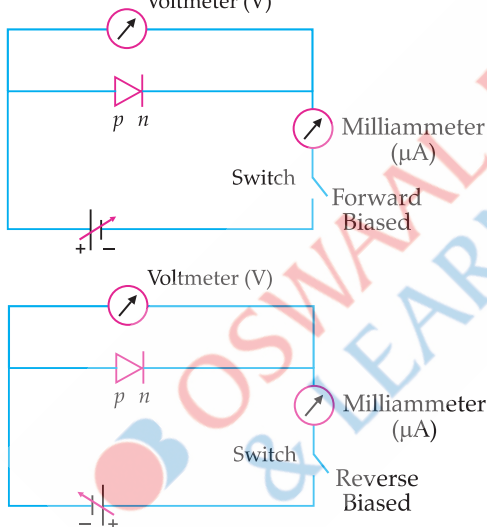

(b)

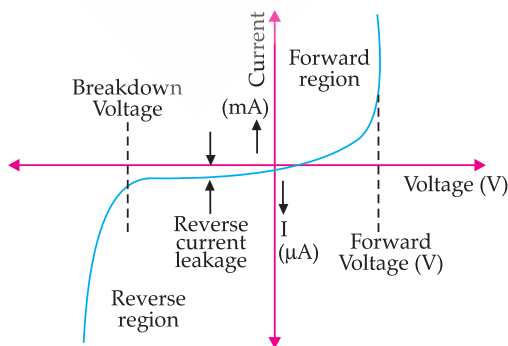

(c) Information from V to I Characteristics:

Threshold Voltage: The minimum forward voltage required for the diode to conduct significantly ($\approx 0.7 \text{ V}$ for silicon, 0.3 V for germanium).

Breakdown Voltage: The reverse voltage at which the diode conducts heavily due to breakdown effects.

SECTION - D

29.

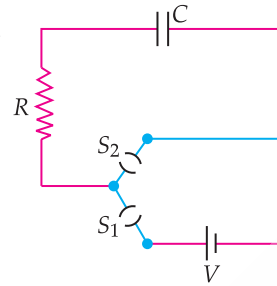

$$\begin{aligned}q &= Q(1 - e^{-t/RC}) \\ R &= 20 \text{ k}\Omega \\ C &= 500 \mu\text{F} \\ V &= 10 \text{ V}\end{aligned}$$

- (i) Option (B) is correct.

Explanation: The final charge on the capacitor, when the key S_1 is closed and S_2 is open:

$Q = CV$ (As the battery will charge capacitor to its full capacity)

$$\begin{aligned}Q &= 500 \times 10^{-6} \times 10 \\ Q &= 5 \text{ mC}.\end{aligned}$$

- (ii) Option (A) is correct.

Explanation: As S_1 is open, the capacitor will discharge through resistor completely. So, final charge on the capacitor is zero.

- (iii) Option (D) is correct.

Explanation: $[RC] = [ML^2T^{-3}A^{-2}][M^{-1}L^{-2}T^4A^2]$
 $= [M^0L^0TA^0]$

- (iv) Option (A) is correct.

Explanation: $q = Q(1 - e^{-t/RC})$
 $I = \frac{dq}{dt}$

$$\text{Time constant} = RC = 20 \text{ k}\Omega \times 500 \mu\text{F} = 10$$

$$I = 5 \times \frac{e^{-\frac{5}{10}}}{10} = \frac{1}{2\sqrt{e}} \text{ mA}$$

OR

- (iv) Option (B) is correct.

Explanation: $I = \frac{dq}{dt} = Q(0 - e^{-t/\tau})\left(-\frac{1}{\tau}\right)$

$$I = \frac{Q}{\tau} e^{-\frac{t}{\tau}}$$

\Rightarrow

$$I = \frac{CV}{RC} e^{-\frac{t}{\tau}}$$

$$I = \frac{V}{R} e^{-\frac{t}{\tau}}$$

$$= I_0 e^{-\frac{t}{\tau}}$$

$$I_0 = \frac{V}{R}$$

$$= \frac{10\text{V}}{20\text{k}\Omega} = 0.5 \text{ mA}$$

30. (i) Option (D) is correct.

Explanation:

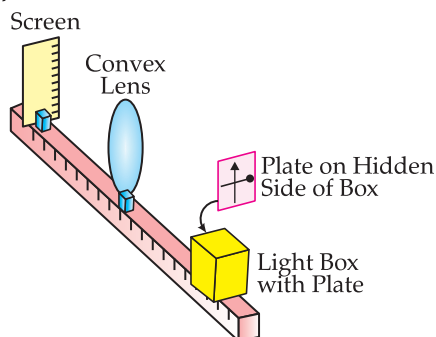

The given setup involves an object (a painted glass plate) placed in front of a convex lens, and its real image is projected onto a screen. The object consists of:

- A **black vertical arrow**.
- A **horizontal thick line with a ball**.

Since, a **convex lens** forms a real, **inverted** image when an object is placed beyond the focal point, the image formed on the screen will be:

1. **Inverted vertically:** The arrow pointing upwards in the object will now point downwards in the image.
2. **No horizontal inversion:** The left-right orientation remains the same.
3. **The ball's position will remain on the same side.**

The correct representation of the real image formed on the screen is **option (D)** because it correctly shows the **vertical inversion** while maintaining the **same horizontal orientation**.

(ii) Option (A) is correct.

Explanation:

(A) "For a convex mirror, magnification is always negative." So, it is incorrect.

- Convex mirrors always form **virtual, upright images**, so magnification is **positive (B)** "For all virtual images formed by a mirror, magnification is positive." So, it is correct.
- Virtual images are always upright, so magnification is **positive**.

(C) "For a concave lens, magnification is always positive." So, it is correct.

- Concave lenses always form **virtual, upright, and diminished** images, meaning **positive magnification**.

(D) "For real and inverted images, magnification is always negative." So, it is correct.

- Real and inverted images have **negative magnification**.

(iii) Option (A) is correct.

Explanation: The lens formula remains the same for each half-lens because the curvature of the surfaces is unchanged.

Since, the refractive power of the lens depends only on the curvature and refractive index, the focal length of each part remains the same as the original lens.

Final answer : f

OR

(iii) Option (B) is correct.

Explanation:

$$\frac{1}{f} = \frac{1}{v} - \frac{1}{u}$$

$$f = \frac{uv}{u-v}$$

$$f = \frac{30(-20)}{-20-30} = 12 \text{ cm}$$

(iv) Option (C) is correct.

Explanation: Object distance $u = -(X_1 + f)$

Image distance $v = X_2 + f$

From Lens formula:

$$\frac{1}{f} = \frac{1}{v} - \frac{1}{u}$$

$$\frac{1}{f} = \frac{1}{X_2 + f} - \frac{1}{-(X_1 + f)}$$

$$\frac{1}{f} = \frac{1}{X_2 + f} + \frac{1}{X_1 + f}$$

$$\frac{1}{f} = \frac{(X_2 + f) + (X_1 + f)}{(X_2 + f)(X_1 + f)}$$

$$1 = \frac{f(X_1 + X_2 + 2f)}{(X_2 + f)(X_1 + f)}$$

$$(X_2 + f)(X_1 + f) = f(X_1 + X_2 + 2f)$$

$$X_1X_2 + f^2 = 2f^2$$

$$X_1X_2 = f^2$$

$$f = \sqrt{X_1X_2}$$

SECTION - E

31. (i) Two point charges are given as:

$$q_1 = 5 \mu\text{C} = 5 \times 10^{-6} \text{ C at } (-3 \text{ cm}, 0, 0) \\ = (-0.03 \text{ m}, 0, 0)$$

$$q_2 = -1 \mu\text{C} = -1 \times 10^{-6} \text{ C at } (3 \text{ cm}, 0, 0) \\ = (0.03 \text{ m}, 0, 0)$$

An external electric field is given by:

$$E = \frac{A}{r^2}, A = 3 \times 10^5 \text{ Vm}$$

The change in electrostatic energy of a system of charges in an external field is given by:

$$\Delta U = -\sum q_i E(x_i) x_i$$

Since, the given electric field is position-dependent:

$$E(x) = \frac{A}{x^2}$$

For charge $q_1 = 5 \mu\text{C}$ at $x_1 = -0.03 \text{ m}$

$$E_1 = \frac{A}{x_1^2} = \frac{3 \times 10^5}{(-0.03)^2}$$

$$= 3.33 \times 10^8 \text{ V/m}$$

For charge $q_2 = -1 \mu\text{C}$ at $x_2 = 0.03 \text{ m}$

$$E_2 = \frac{A}{x_2^2} = \frac{3 \times 10^5}{(0.03)^2} = 3.33 \times 10^8 \text{ V/m}$$

Change in electrostatic energy: $\Delta U = \Delta U_1 + \Delta U_2$

$$\Delta U = -q_1 E_1 x_1 - q_2 E_2 x_2$$

$$\Delta U = -(5 \times 10^{-6})(3.33 \times 10^8)(-0.03) - (-1 \times 10^{-6})(3.33 \times 10^8)(0.03) = 0.06 \text{ J}$$

$$(ii) (1) \quad C = Q/V$$

$$C = \frac{80 \times 10^{-6}}{16} = 5 \times 10^{-6} \text{ F} = 5 \mu\text{F}$$

$$(2) \quad C' = KC = 3 \times 5 \mu\text{F} = 15 \mu\text{F}$$

$$V' = \frac{80 \times 10^{-6}}{15 \times 10^{-6}} = 5.33 \text{ V}$$

(3) **Capacitance depends only on the physical properties** (geometry, medium, plate separation), not on charge. Since, there is **no change in plate configuration or medium, the capacitance remains 5 μF .**

Thus, the capacitance does not change.

OR

(i) Three conducting spherical shells A, B, and C, each of radius R , have inner concentric metal balls of radius $R/10$.

Given charges: Shell A: $+6q$, Inner Ball A: $-2q$; Shell B: $-4q$, Inner Ball B: $+8q$; Shell C: $+14q$, Inner Ball C: $-10q$

Distance where the field is to be calculated: $3R$.

For a conducting spherical shell, the total charge appears as if it is concentrated at the centre when calculating the field outside the shell. The inner ball induces charges on the inner surface of the shell, but the total charge on the outer shell remains the same. Thus, the net charge on each shell determines the electric field at $3R$.

Shell A:

Net charge on the shell itself = $+6q$.

Shell B:

Net charge on the shell itself = $-4q$.

Shell C:

Net charge on the shell itself = $+14q$.

Now the electric fields at a distance $3R$ are given by

$$\frac{k6q}{(3R)^2} : \frac{k4q}{(3R)^2} : \frac{k14q}{(3R)^2}$$

$$6 : 4 : 14$$

$$\text{i.e., } 3 : 2 : 7$$

(ii) Electric potential at any point due to a charge q at a distance r :

$$V = kq/r$$

Since, **C and A are at the same distance from B** (radius = 5 cm), the potential at both points due to B and D is the same.

Thus, the potential difference between C and A is zero, meaning:

$$W = q \Delta V = 0$$

32. (a) (i) A proton is a **positively charged particle**, and its trajectory is influenced by the Lorentz force in a magnetic field. The force on a charged particle in a magnetic field is given by:

$$\vec{F} = q(\vec{v} \times \vec{B})$$

Since, the force is always perpendicular to the velocity, the particle follows a **curved path**. The nature of curvature indicates the direction and variation in the magnetic field.

The proton follows a **curved trajectory that remains in the plane of the paper**.

This suggests that the force acting on the proton is **perpendicular** to its velocity in the plane.

Since, the proton curves **upward**, the force must be **towards the centre of curvature**, meaning the magnetic field is **into the plane of the paper** at all points using right-hand rule.

Thus, at points **P, Q, and R**, the magnetic field is directed into the paper.

The radius of curvature r of a charged particle's motion in a magnetic field is given by:

$$r = \frac{mv}{qB}$$

If the radius is **larger**, the magnetic field is **weaker**. If the radius is **smaller**, the magnetic field is **stronger**.

Observing the trajectory:

- At **P**, the path is relatively straight, meaning **B is smaller**.
- At **Q**, the curvature increases, meaning **B is increasing**.
- At **R**, the curvature is highest, meaning **B is largest**.

Thus, the relative magnitude follows: $B_P < B_Q < B_R$

(ii) The **magnetic moment** (μ) of a current-carrying circular loop is given by:

$$\mu = IA$$

The magnetic field at the centre of a circular loop carrying current is given by:

$$B = \frac{\mu_0 I}{2R}$$

The area of the loop is:

$$A = \pi R^2 \Rightarrow R = \sqrt{\frac{A}{\pi}}$$

Now, substitute R back into the equation for B :

$$B = \frac{\mu_0 I}{2\sqrt{\frac{A}{\pi}}}$$

This simplifies to: $B = \frac{\mu_0 I \sqrt{\pi}}{2\sqrt{A}}$

Rearranging the equation to solve for I :

$$I = \frac{2B\sqrt{A}}{\mu_0 \sqrt{\pi}}$$

The magnetic moment m of the loop is given by:

$$m = IA$$

Substituting the expression for I :

$$m = \left(\frac{2B\sqrt{A}}{\mu_0 \sqrt{\pi}} \right) A$$

This simplifies to: $m = \frac{2BA\sqrt{A}}{\mu_0 \sqrt{\pi}}$

OR

- (b) (i) Consider the simple case when a rectangular loop is placed in a uniform magnetic field B that is in the plane of the loop.

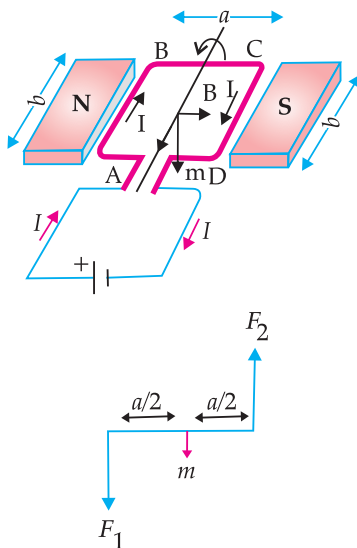

Force on arm $AB = F_1 = IbB$ (directed into the plane of the loop)

Force on arm $CD = F_2 = IbB$ (directed outward the plane of the loop)

Therefore, the magnitude of the torque on the loop due to these pair of forces is

$$\tau = F_1 \frac{a}{2} + F_2 \frac{a}{2}$$

$$= I(ab)B$$

$$= IAB = mB$$

($A = ab =$ area of the loop)

Alternatively,

Also, accept if the student obtains the result.

$$\text{Torque} = IAB \sin \theta$$

- (ii) (1) The radius of a charged particle moving in a uniform magnetic field is given by:

$$r = \frac{mv}{qB}$$

The initial kinetic energy of the particle:

$$K_i = \frac{1}{2}mv_i^2$$

After losing half of its kinetic energy:

$$K_f \left(\frac{1}{2}mv_f^2 \right) = \frac{1}{2}K_i = \frac{1}{2} \left(\frac{1}{2}mv_i^2 \right)$$

$$v_f = \frac{v_i}{\sqrt{2}}$$

$$r = \frac{mv}{qB}$$

$$r_f = \frac{mv_f}{qB}$$

$$= \frac{mv_i}{qB\sqrt{2}} = \frac{1}{\sqrt{2}}r_i$$

Hence, the radius decreases by a factor of $\frac{1}{\sqrt{2}}$.

- (2) The time period of revolution for a charged particle in a magnetic field is given by:

$$T = \frac{2\pi m}{qB}$$

Since, the time period does not depend on velocity, it remains unchanged even though the kinetic energy is reduced.

33. (i) (1) Coherent sources are sources of light or waves that emit waves with a constant phase relationship over time. This means the phase difference between the waves remains constant or changes in a predictable way.

Coherent sources are necessary for observing a sustained interference pattern because interference occurs due to the superposition of waves. If the sources are not coherent, the phase difference between the waves will change randomly over time, leading to a rapidly fluctuating interference pattern which cannot be sustained.

- (2) Two light sources are said to be incoherent or not coherent when there is no constant phase relationship between them. In other words, the phase difference between the two sources changes randomly over time. This causes the interference pattern to be unstable, and the maxima and minima of the pattern to fluctuate, making it impossible to maintain a sustained pattern.

- (ii) The distance between adjacent bright fringes (fringe width) in a double-slit interference pattern is given by the formula:

$$y = \frac{\lambda D}{d}$$

where, y is the distance between adjacent bright fringes, λ is the wavelength of light, D is the distance between the slits and the screen, d is the separation between the slits.

- (1) $\lambda = 600 \text{ nm}$
 $D = 1.20 \text{ m}$
 $d = 0.1 \text{ mm}$

$$y = \frac{600 \times 10^{-9} \times 1.20}{0.1 \times 10^{-3}} = 7.2 \text{ mm}$$

- (2) The angular width θ of the first bright fringe is given by:

$$\theta = \frac{\lambda}{d} = \frac{600 \times 10^{-9}}{0.1 \times 10^{-3}}$$

$$= 6 \times 10^{-3} \text{ radian}$$

$$\theta = 6 \times 10^{-3} \times \frac{180}{\pi} \approx 0.34^\circ$$

OR

- (b) (i) A wavefront is the locus of points that are in the same phase of vibration. In simpler terms, it is the surface of constant phase where all points on the wavefront are at the same distance from the source.

In the case of an incident plane wave falling on a convex lens, the wavefront bends (refracts) as

it passes through the lens. The convex lens converges parallel rays of light, changing the wave-front's shape.

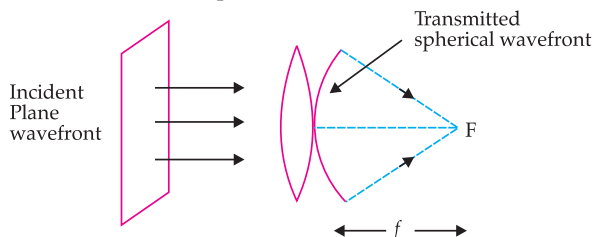

(ii) Using **Refraction at a Spherical Surface Formula** to determine the image position for First Refraction:

$$\frac{n_1}{v'} - \frac{n_2}{u} = \frac{(n_1 - n_2)}{R}$$

where:

- $n_1 = 1.0$ (refractive index of air),
- $n_2 = 1.5$ (refractive index of glass),
- $u = \infty$ (since, the light comes from a distant source),
- $R = +15$ cm (radius of curvature, positive as the surface is convex),
- v' is the image distance inside the sphere.

After putting values,

$$\frac{1.0}{v'} - \frac{1.5}{15} = \frac{(1.0 - 1.5)}{-15}$$

Solving for $v' = 45$ cm

Thus, the image of the distant object due to the first refraction **forms at 45 cm inside the sphere** from the first refracting surface.

Now, the light travels inside the sphere and undergoes refraction at the second (convex) surface when it exits into air.

Using the same formula at the second interface:

$$\frac{n_1}{v'} - \frac{n_2}{u} = \frac{(n_1 - n_2)}{R}$$

where:

- $n_2 = 1.5$ (glass),
- $n_1 = 1.0$ (air),
- $u = +45 - 30$ cm (the object distance from the second surface),
- $R = -15$ cm (negative because it is convex relative to exiting rays),
- v' is the final image distance.

After putting values ,

$$\frac{1.0}{v'} - \frac{1.5}{15} = \frac{(1.0 - 1.5)}{-15}$$

Solving for v' , $v' = 7.5$ cm

Thus, Final image is formed at 7.5 cm from second surface and 22.5 cm from centre of sphere.

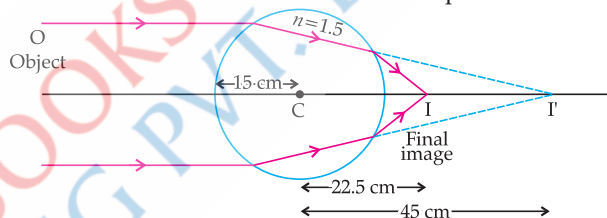

Delhi Set-2

SECTION - A

1. Option (C) is correct.

Explanation: Work done = $\Delta V \times Q$

Work done does not depend up on path travel because electric field is a conservative field.

Thus, $W(A) = (10 - 10) \times Q = 0$

$W(B) = (15 - 10) \times Q$
 $= 5Q$

$W(C) = (25 - 10) \times Q$
 $= 15Q$

$W(D) = (20 - 10) \times Q$
 $= 10Q$

Thus, maximum work is in option C.

2. Option (B) is correct.

Explanation: We know that resistance of a wire is directly proportional to the length of the wire.

If the radius of the wire is kept fixed and the length of the wire becomes half, then the resistance of the wire will also be halved. (As the resistivity is constant according to the question)

4. Option (C) is correct.

Explanation: Given Data:

Diameter of the coil = 0.015 m

Number of turns = 300

Initial Magnetic Field = $B_i = 30$ mT = 0.030 T

Final Magnetic Field = $B_f = 0$ T (for first interval)

Time for first interval = 20 ms = 0.020 s

Time for second interval = 40 ms = 0.040 s

Magnetic flux through a single turn of the coil is:

$$\phi = B A$$

Area of the coil: $A = \pi r^2 = \pi \left(\frac{d}{2}\right)^2 = \pi \left(\frac{0.015}{2}\right)^2$

$$A = 1.767 \times 10^{-4} \text{ m}^2$$

First Interval (Field reduces from 30 mT to 0 in 20 ms)

The induced emf is:

$$e_1 = N \frac{\Delta \phi}{\Delta t} = N \frac{A(B_f - B_i)}{\Delta t}$$

Substituting values:

$$e_1 = 300 \times \frac{(1.767 \times 10^{-4}) \times (0 - 0.030)}{0.020}$$

$$e_1 = -0.795 \text{ V}$$

Second Interval (Field increases from 0 to 30 mT in 40 ms)

$$e_2 = N \frac{\Delta \phi}{\Delta t} = N \frac{A(B_f - B_i)}{\Delta t}$$

$$\frac{e_1}{e_2} = 2$$

$$e_2 = 0.398 \text{ V}$$

Calculate $\frac{e_1}{e_2}$

$$\frac{e_1}{e_2} = 0.3980.795 \approx 2$$

Final Answer: $\frac{e_1}{e_2} = 2$

7. Option (B) is correct.

Explanation: Speed of waves remains constant. Wave length is more in micro-wave and frequency is more in X-rays. Hence, [Option B] is correct.

8. Option (C) is correct.

Explanation: Refractive index $\mu = \frac{c}{v}$

Thus,
$$\mu_1 = \frac{c}{v_1}$$

$$\mu_2 = \frac{c}{v_2}$$

Since, $v_1 > v_2$, Thus $\mu_1 < \mu_2$

Now, for TIR (total internal reflection), light must go from denser to a rarer medium. Thus, light must go from medium 2 to 1.

And angle of incidence must be greater than critical angle. Now the critical angle $i_c = \sin^{-1}\left(\frac{\mu_1}{\mu_2}\right)$

Thus
$$\frac{\mu_1}{\mu_2} = \frac{v_2}{v_1}$$

9. Option (A) is correct.

Explanation: Given: $v = 5 \times 10^{14}$ Hz

$$\begin{aligned} E &= hv \\ &= 6.63 \times 10^{-34} \times 5 \times 10^{14} \\ &= 33.15 \times 10^{-20} \text{ J} \end{aligned}$$

Now
$$\begin{aligned} n &= \frac{P}{E} \\ &= \frac{3.31 \times 10^{-3}}{33.15 \times 10^{-20}} \\ &\approx \frac{1}{10} \times 10^{17} \\ &\approx 10^{16} \end{aligned}$$

SECTION - B

17.
$$E = \rho J$$

Since,
$$J = \frac{I}{A}$$

Thus,
$$E = \frac{\rho I}{A}$$

Multiply with L in numerator and denominator

$$E = \left(\frac{\rho I}{A}\right) \times \left(\frac{L}{L}\right) \text{ and } \frac{\rho L}{A} = R$$

$$E = R \times \frac{I}{L}$$

Thus,
$$E \times L = R \times I$$

Since,
$$E \times L = V$$

Thus $V = IR$ which is Ohm's law. **Hence proved.** Ohm's law is not valid in case if the resistance is variable.

19. Given
$$\begin{aligned} R_1 &= R_2 \\ u &= -\frac{R}{2} \\ \mu_1 &= 1 \\ \mu_2 &= 1.5 \end{aligned}$$

To find v

$$\frac{\mu_2}{v} - \frac{\mu_1}{u} = \left(\frac{\mu_2 - \mu_1}{R}\right)$$

Substituting values we will get $v = -R$

The nature of the image will be real and inverted.

20. For a hydrogen atom,

$$E = -\frac{13.6}{n^2}$$

Thus
$$-3.4 = -\frac{13.6}{n^2}$$

Hence
$$n = 2$$

Also
$$L = \frac{nh}{2\pi}$$

Hence, putting $n = 2, h = 6.63 \times 10^{-34}$

We get
$$L = 2.11 \times 10^{-34} \text{ S.I. units}$$

SECTION - C

23. (a) The magnetic moment of a current-carrying coil is a vector quantity representing the strength and direction of the magnetic field produced by the coil, defined as the product to the current flowing through the coil and the area enclosed by the loop, and its SI unit is ampere-square metre ($A \cdot m^2$)

(b) Given,
$$\begin{aligned} N &= 60 \\ A &= 1.5 \times 10^{-3} \text{ m}^2 \\ I &= 2 \text{ A} \\ \tau_1 &= 0.12 \end{aligned}$$

(when orientation is at θ)

$$\tau_2 = 0.05$$

when orientation is at $(90 + \theta)$

Thus, using formula for torque on coil

Applying Torque for Two Cases

$$\tau = NIAB \sin\theta$$

$$\tau_1 = NIAB \sin(\theta) \quad \dots(1)$$

$$\begin{aligned} \tau_2 &= NIAB \sin(90 + \theta) \\ &= NIAB \cos(\theta) \quad \dots(2) \end{aligned}$$

Dividing both equations

$$\tan(\theta) = \frac{\tau_1}{\tau_2} = 2.4$$

Thus,
$$\sin(\theta) = 0.92$$

Putting in Eq. (1)

$$B = 0.724 \text{ T}$$

24. Let l = length of each solenoid
 r_1, r_2 = radii of the two solenoids

$$A = \pi r_1^2$$

= area of cross-section of inner solenoid S_1

N_1, N_2 = number of turns in the two solenoids

First we pass a time varying current I_2 through S_2 .

The magnet field set up inside S_2 due to I_2 is

$$B_2 = \mu_0 n_2 I_2$$

where $n_2 = N_2/l =$ the number of turns per unit length of S_2 .

Total magnetic flux linked with the inner solenoid S_1 is

$$\phi_1 = B_2 AN_1 = \mu_0 n_2 I_2 \cdot AN_1$$

\therefore Mutual inductance of coil 1 with respect to coil 2 is

$$\begin{aligned} M_{12} &= \frac{\phi_1}{I_2} \\ &= \mu_0 n_2 AN_1 \\ &= \frac{\mu_0 N_1 N_2 A}{l} \end{aligned}$$

We now consider the flux linked with the outer solenoid S_2 due to the current I_1 in the inner solenoid S_1 . The field B_1 due to I_1 is constant inside S_1 but zero in the annular region between the two solenoids. Hence $B_1 = \mu_0 n_1 I_1$

where $n_1 = N_1/l =$ the number of turns per unit length of S_1 .

Total flux linked with the outer solenoid S_2 is

$$\begin{aligned} \phi_2 &= B_1 AN_2 = \mu_0 n_1 I_1 \cdot AN_2 \\ &= \frac{\mu_0 N_1 N_2 A I_1}{l} \end{aligned}$$

\therefore Mutual inductance of coil 2 with respect to coil 1 is

$$\begin{aligned} M_{21} &= \frac{\mu_0 N_1 N_2 A}{l} \\ M_{12} &= M_{21} = M \text{ (say)} \end{aligned}$$

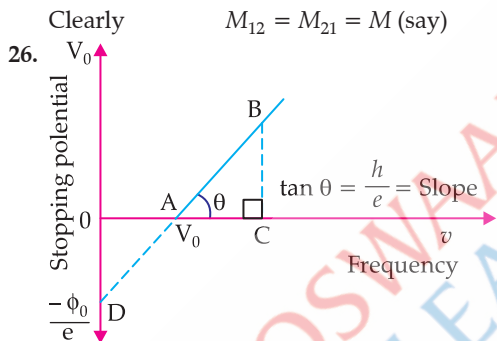

A plot of frequency versus stopping potential would show a linear relationship with a positive slope,

where the y -axis represents the stopping potential and the x -axis represents the frequency; the intercept on the y -axis provides information about the work function of the material, specifically, the negative value of the work function divided by the electron charge ($-\phi/e$) as it represents the stopping potential at zero frequency (threshold frequency) where no photoelectrons are emitted.

$$eV_0 = hv - \phi$$

Rearranging

$$V_0 = \left(\frac{h}{e}\right)v - \frac{\phi}{e}$$

$$y = mx + c$$

$$Y\text{-intercept} = c = -\frac{\phi}{e}$$

(b) Given $K = 80\text{eV} = 128 \times 10^{-19}\text{J}$

Using relation: $p = \sqrt{2Km}$

where $m =$ mass of electron $= 9.1 \times 10^{-31}\text{kg}$

Substituting the values:

$$p = \sqrt{2 \times (9 \times 10^{-31}\text{kg}) \times (1.28 \times 10^{-17}\text{J})}$$

Calculating inside the square root:

$$\begin{aligned} p &= \sqrt{2 \times 9 \times 1.28 \times 10^{-48}} \\ &= \sqrt{23.04 \times 10^{-48}} \\ &= 4.8 \times 10^{-24}\text{kg m/s} \end{aligned}$$

The de Broglie wavelength λ is given by the formula:

$$\lambda = \frac{h}{p}$$

Where h is Planck's constant $= 6.6 \times 10^{-34}\text{J s}$.

Substituting the values:

$$\lambda = \frac{6.6 \times 10^{-34}\text{J s}}{4.8 \times 10^{-24}\text{kg m/s}}$$

Calculating the wavelength:

$$\lambda = 1.375 \times 10^{-10}\text{m} = 1.3\text{\AA}$$

SECTION - A

1. Option (A) is correct.

Explanation: The acceleration ' a ' of charge ' q ' due to the fixed charge Q is given by Coulomb's law:

$$F = \frac{kQq}{r^2}$$

Since, acceleration is given by Newton's second law:

$$a = \frac{F}{m} = \frac{kQq}{mr^2}$$

From this equation, we see that acceleration ' a ' is inversely proportional to r^2

So, a is largest when r is the smallest and decreases rapidly as r increases and the graph should resemble

a hyperbola with the form $a = \frac{C}{r^2}$, where C is a constant.

2. Option (A) is correct.

Explanation: Since, the conductors are connected in parallel, the voltage across them is the same:

$$V_A = V_B$$

The electric field is given by $E = \frac{V}{L}$

The ratio of the electric fields is:

$$\frac{E_A}{E_B} = \frac{\frac{V_A}{L_A}}{\frac{V_B}{L_B}} = \frac{V_A}{L_A} \cdot \frac{L_B}{V_B}$$

Since, $V_A = V_B$, $\frac{E_A}{E_B} = \frac{L_B}{L_A}$

Given $\frac{L_A}{L_B} = \frac{1}{2}$, then $\frac{L_B}{L_A} = 2$

Therefore, $\frac{E_A}{E_B} = 2$

The drift velocity is given by $v_d = \mu E$.

Since, the conductors are made of the same material, the mobility μ is the same for both.

The ratio of the drift velocities is:

$$\frac{v_{dA}}{v_{dB}} = \frac{\mu E_A}{\mu E_B} = \frac{E_A}{E_B}$$

Therefore, $\frac{v_{dA}}{v_{dB}} = 2$

4. Option (D) is correct.

Explanation: Given Data:

Turns ratio: $N_s : N_p = 20:1$

Primary voltage: $V_p = 240$ V

Load resistor: $R = 6.0 \Omega$

Transformation ratio

$$\frac{V_p}{V_s} = \frac{N_p}{N_s}$$

$$V_s = \frac{240}{20} = 12 \text{ V}$$

$$I_s = \frac{V_s}{R_s} = \frac{12}{6} = 2 \text{ A}$$

For ideal transformation

$$V_p I_p = V_s I_s$$

$$240 \times I_p = 12 \times 2$$

$$I_p = \frac{24}{240} = 0.10 \text{ A}$$

7. Option (B) is correct.

Explanation: X-ray has much shorter wavelength and higher energy than UV rays.

8. Option (B) is correct.

Explanation:

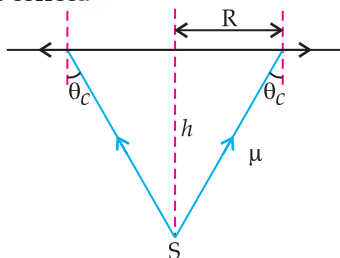

Using basic trigonometry, the radius R of this circular patch is:

$$R = H \tan \theta_c = \frac{H \sin \theta_c}{\cos \theta_c}$$

$$\Rightarrow R = \frac{H \sin \theta_c}{\sqrt{1 - \sin^2 \theta_c}}$$

Since, $\sin \theta_c = \frac{1}{\mu}$

$$\therefore R = \frac{H}{\sqrt{\mu^2 - 1}}$$

So, the area $\pi R^2 = \frac{\pi H^2}{\mu^2 - 1}$

9. Option (C) is correct.

Explanation: $K_{max} = eV_s = (1 \times 2.5)\text{eV} = 2.5 \text{ eV}$

SECTION - B

17. Number of cells = n

EMF of each cell = E

Internal resistance of each cell = r

All the cells are in series.

Thus, total internal resistance, $R = nr$

Total EMF, $e = nE$

As the two cells are connected in reverse polarity, these two cells will cancel-out the contribution of other two cells in the loop.

Then, the net EMF across the circuit will be

$$E_{eq} = nE - 4E$$

The current I in the circuit = $\frac{nE - 4E}{nr}$

Voltage across the opposite connected batteries,

$$V = E - Ir$$

$$V = E - \frac{E(n-4)}{nr} \times r$$

$$V = \frac{4E}{n}$$

19. Lens makes formula for double convex lens

$$\frac{1}{f} = \left(\frac{n_g}{n_w} - 1 \right) \left(\frac{1}{R_1} - \frac{1}{R_2} \right)$$

$$n = \frac{n_g}{n_w} = \frac{1.5}{1.33} = 1.127$$

$$\frac{1}{f} = (1.127 - 1) \left(\frac{1}{17} - \frac{1}{-17} \right)$$

$$\frac{1}{f} = 0.127 \times \frac{2}{17}$$

$$\frac{1}{f} = \frac{0.254}{17} = 0.01494$$

So, $f = 67 \text{ cm}$

20. Energy of an electron

$$\epsilon_n = \frac{-13.6}{n^2} \text{ eV}$$

for ϵ_i $-1.51 = \frac{-13.6}{n_i^2}$

$$\Rightarrow n_i^2 = \frac{-13.6}{-1.51} \approx 9$$

$$\text{for } \epsilon_f \quad -3.40 = \frac{-13.6}{n_f^2}$$

$$\Rightarrow n_f^2 = \frac{-13.6}{-3.40} \approx 4$$

Bohr radius

$$r_n = n^2 r_1$$

$$\text{So } r_i = n_i^2 r_1 = 9 \times 0.53 = 4.77 \text{ \AA}$$

$$r_f = n_f^2 r_1 = 4 \times 0.53 = 2.12 \text{ \AA}$$

$$\text{Change in radius } \Delta r = 4.77 - 2.12 = 2.65 \text{ \AA}$$

SECTION - B

23. (a) Magnetic field \vec{B}

According to Ampere's law

$$B = \frac{\mu_0 I}{2\pi d}$$

direction is determined by right hand rule, magnetic field direction is along negative direction

$$\vec{B} = \frac{\mu_0 I}{2\pi d} \hat{j}$$

(b) Magnetic force \vec{F}_m

charge is many along $-x$ direction

$$\text{so } \vec{v} \times \vec{B} = -(v\hat{i}) \times \left(\frac{\mu_0 I}{2\pi d} \hat{j} \right)$$

$$\vec{F}_B = qv \left(-\frac{\mu_0 I}{2\pi d} \hat{k} \right)$$

So direction of magnetic force is negative.

(c) Electric field \vec{E}

Charge is moving undeviated

$$\vec{F}_E + \vec{F}_B = 0$$

$$\vec{F}_E = q\vec{E}$$

$$\Rightarrow q\vec{E} = -\left(-\frac{qv\mu_0 I}{2\pi d} \hat{k} \right)$$

$$\vec{E} = \frac{v\mu_0 I}{2\pi d} \hat{k}$$

24.

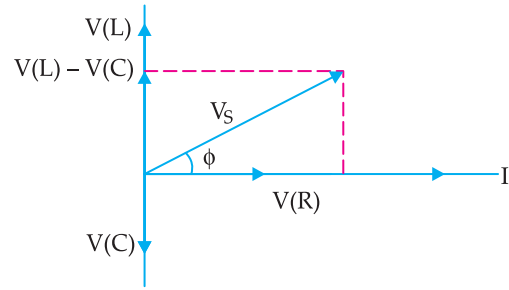
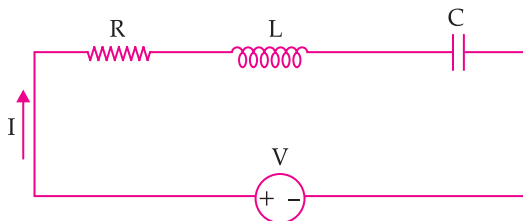

From definition of impedance

$$\text{for inductance } V_L = I X_L = I\omega L$$

$$\text{for capacitor } V_C = I X_C = \frac{I}{\omega C}$$

$$\text{for resistor, } V_R = IR$$

from phasor diagram

$$V_S^2 = V_R^2 + (V_L - V_C)^2$$

$$(IZ)^2 = (IR)^2 + \left(I\omega L - \frac{I}{\omega C} \right)^2$$

$$Z = \sqrt{R^2 + \left(\omega L - \frac{1}{\omega C} \right)^2}$$

as resonance, impedance is minimum

for $V_C > V_L$, circuit is capacitive

for $V_L > V_C$, circuit is inductive

$$I = \frac{V}{Z} \sin(\omega t - \phi)$$

and

$$\theta = \tan^{-1} \left(\frac{X_L - X_C}{R} \right)$$

26. (a) Here, are three key experimental results that could not be explained by the wave theory:

1. Instantaneous Emission of Photoelectrons:

Electrons are emitted immediately after light strikes the metal surface, without any delay, no matter how weak the light source is. According to wave theory, energy should be gradually absorbed over time, causing a delay in electron emission. This does not happen.

2. Existence of a Threshold Frequency:

Photoelectrons are only emitted if the light frequency f is above a certain threshold frequency f_0 , regardless of the intensity of light. Wave theory suggests that a higher intensity (brighter light) should always provide enough energy for electrons to escape, even at low frequencies. However, no electrons are emitted below f_0 , contradicting wave theory.

3. Kinetic Energy of Electrons Depends on Frequency, Not Intensity:

The maximum kinetic energy of emitted electrons increases with the frequency of light but is independent of intensity. Wave theory predicts that increasing light intensity should increase energy transfer to electrons, increasing their kinetic energy. Instead, only higher frequencies result in higher kinetic energy.

- (b) Slope of cut off voltage (
- V_s
-) Vs frequency is given

$$\text{Slope} = 4.12 \times 10^{-15} \text{ Vs}$$

Einstein photoelectric equation

$$eV_s = hf - \phi$$

$$\text{or } V_s = \frac{hf}{e} - \frac{\phi}{e}$$

$$\text{also slope} = \frac{h}{e}$$

$$\therefore \frac{h}{e} = 4.12 \times 10^{-15} \text{ Vs}$$

$$h = 4.12 \times 10^{-15} \times 1.6 \times 10^{-19} \\ = 6.592 \times 10^{-34} \text{ Js}$$

$$h \approx 6.63 \times 10^{-34} \text{ Js}$$

Outside Delhi Set-1

55/2/1

SECTION – A

1. Option (D) is correct.

Explanation: The net electric field at point C will point vertically upwards, along the line perpendicular to AB, and towards the midpoint of AB (point M), i.e., along the line CM.

2. Option (C) is correct.

Explanation: By connecting two resistors in series (giving a total resistance of $2R$) and then placing this combination in parallel with the third resistor (which has resistance R), the net resistance we get is $\frac{2R}{3}$, which is the desired resistance.

3. Option (D) is correct.

Explanation: Using Biot-Savart law: $dB = \frac{\mu_0 Idl \times r}{4\pi r^3}$

Given $I = 1\text{A}$, $dl = 0.01\text{ m}$. Observation point: $P(1, 1, 0)$,
 $r = \sqrt{1^2 + 1^2} = \sqrt{2}$

For a small element at $x = 0$: $dl \times r = dx \hat{k}$

$$\text{Magnetic field } B = \frac{\mu_0}{4\pi} \cdot \frac{dx \hat{k}}{r^3}$$

$$\text{Substituting values: } B = \frac{10^{-7} \times 0.01 \hat{k}}{(\sqrt{2})^3}$$

$$B = \frac{10^{-9} \hat{k}}{2\sqrt{2}}$$

$$\text{Approximating: } B = \frac{-5.02}{\sqrt{2}} \times 10^{-10} \hat{k} \text{ T}$$

4. Option (A) is correct.

Explanation: The magnetic field B due to a small magnetic dipole with a dipole moment M at a point located along the axis of the dipole (i.e., on the axis of symmetry of the dipole) at a distance ' r ' from the centre of the dipole is given by the formula:

$$B = \frac{\mu_0}{4\pi} \cdot \frac{2M}{r^3}$$

5. Option (C) is correct.

Explanation: When the magnet enters the pipe, the current flows from Y to Z (trying to oppose the magnet entering). When the magnet exits the pipe, the current flows from Z to Y (trying to oppose the magnet exiting).

6. Option (C) is correct.

Explanation: To determine the correct voltage waveform, we use the relationship between voltage and current in an inductor: $V = L di/dt$

The given graph shows a triangular waveform for

current (I) where, from $t = 0$ to $t = T/2$, current increases linearly and from $t = T/2$ to $t = T$, current decreases linearly.

The derivative of a linearly increasing function is a constant positive value and the derivative of a linearly decreasing function is a constant negative value.

Thus, the voltage (V) waveform should be a square wave, with constant voltage for each half-cycle.

7. Option (D) is correct.

Explanation: The number of turns in the secondary coil can be found using the transformer turns ratio

$$\text{Formula: } \frac{V_s}{V_p} = \frac{N_s}{N_p}$$

Given, $V_s = 3000\text{ V}$ (secondary voltage)

$V_p = 200\text{ V}$ (primary voltage)

$N_p = 450$ (number of turns in the primary coil)

Rearranging the formula for N_s :

$$N_s = \frac{V_s}{V_p} \times N_p$$

$$N_s = \frac{3000}{200} \times 450$$

$$N_s = 15 \times 450$$

$$N_s = 6750$$

So, the number of turns in the secondary coil is 6750 turns.

8. Option (A) is correct.

Explanation: Electrostatic fields are conservative because the work done in moving a charge between two points is path-independent. Mathematically, $\vec{v} \times \vec{E} = \vec{0}$ and field lines do not form closed loops because they originate from positive charges and terminate at negative charges (or extend to infinity).

9. Option (A) is correct.

Explanation: Using refraction formula:

$$n = \frac{\text{Real depth}}{\text{Apparent depth}} = \frac{30}{16}$$

$$\text{Since, } n = \frac{C}{C_{\text{liquid}}} = \frac{3.0 \times 10^8}{C_{\text{liquid}}}$$

$$C_{\text{liquid}} = 3.0 \times \frac{10^8}{n} = \frac{3.0 \times 10^8}{30/16} = 1.6 \times 10^8 \text{ m/s}$$

10. Option (C) is correct.

Explanation: The hydrogen spectral lines capable of emitting photoelectrons from zinc belong to the Lyman series.

11. Option (D) is correct.

Explanation: Given, $E_n = -0.544\text{ eV}$

The energy of an electron in a hydrogen atom is given by the formula:

$$E_n = \frac{-13.6}{n^2} \text{ eV}$$

$$-0.544 = \frac{-13.6}{n^2}$$

$$n^2 = \frac{13.6}{0.544}$$

$$n^2 = 25$$

$$n = \sqrt{25} = 5$$

12. Option (D) is correct.

Explanation: When the resistance measured between the p and n ends of a p - n junction, diode is high, it means the diode is in reverse bias or an off state (high impedance). In this condition, the diode behaves like a switch that is open (non-conducting state).

13. Option (A) is correct.

Explanation: In a semiconductor diode, the thickness of the depletion layer changes based on external conditions such as applied voltage and the depletion layer thickness depends on several factors, including the type of semiconductor material, doping levels, and, most importantly, the biasing applied to the diode.

14. Option (C) is correct.

Explanation: In Bohr's model of the hydrogen atom, the angular momentum (L) of an electron in the n^{th} orbit is given by: $L = \frac{nh}{2\pi}$. So, the angular momentum

is proportional to the square root of the orbit radius and according to Bohr's model, an electron can transition between any two allowed energy levels by absorbing or emitting a photon of appropriate energy. It is not restricted to jumping only to its nearest orbit; it can make larger transitions as well.

15. Option (C) is correct.

Explanation: Radio waves diffract more than infrared waves because diffraction is stronger for longer wavelengths. Radio waves (metres to kilometres) have much larger wavelengths than infrared waves (micrometres) and radio waves (kHz to GHz) have lower frequencies than infrared waves (THz) and due to their inverse relationship, have longer wavelengths.

16. Option (A) is correct.

Explanation: In an ideal step-down transformer, there is no energy loss, assuming 100% efficiency (no resistance, flux leakage, or eddy currents). Input power equals output power and in a step-down transformer, voltage decreases, but current increases to keep power ($P = VI$) constant in an ideal case.

SECTION – B

17. (a) Given, ratio of their lengths, i.e., $R_1 : R_2 = 2 : 3$
Total current = 15 A.

$$\text{Resistance of a wire: } R = \rho \frac{l}{A}$$

Since, they are connected in parallel, the current divides inversely to their resistances.

$$I_1 : I_2 = \frac{1}{R_1} : \frac{1}{R_2} = 3 : 2$$

Let $I_1 = 3x$ and $I_2 = 2x$

$$3x + 2x = 15$$

$$x = 3$$

By putting value of x

$$I_1 = 9 \text{ A, } I_2 = 6 \text{ A}$$

OR

- (b) **Steady-State Condition:** The capacitor C is fully charged, so no current flows through it (acts as an open circuit).

Potential at Q : Assume $P = 0 \text{ V}$.

By using Kirchhoff's Voltage Law (KVL) in the top branch: $V - IR = V_{(PQ)}$

using KVL in the bottom branch: $2V - I(2R) = V_{(PQ)}$

Solving for I using the outer loop:

$$V - IR = 2V - 2IR$$

$$I = \frac{V}{R}$$

$$V_{PQ} = 0V - 0V = 0V$$

Voltage across capacitor C : Since both P and Q are at the same potential, $V_C = 0 \text{ V}$

18. A phase shift of $2\pi(n-1) \times t/\lambda$ causes the 6th dark fringe to shift to the position of the 8th bright fringe.

$$\text{A dark fringe occurs at: } d \sin \theta = \left(m + \frac{1}{2}\right) \lambda$$

$$\text{A bright fringe occurs at: } d \sin \theta = m \lambda$$

The net shift is given by: $6 + \frac{1}{2} + 2\pi(n-1) \times t/\lambda = 8$

Solving for t : $2\pi(n-1) \times t/\lambda = 1.5 \lambda$

$$t = \frac{3\lambda}{4\pi(n-1)}$$

19. Given, two concave lenses with $f = -8.0 \text{ cm}$ are placed 16 cm apart.

$$\text{Using lens formula: } \frac{1}{f} = \frac{1}{v} - \frac{1}{u}$$

$$\text{Applying for lens A: } \frac{1}{-8} = \frac{1}{v} - \frac{1}{-4}$$

$$\frac{1}{v} = \frac{1}{-8} - \frac{1}{4}$$

$$= \frac{-1}{8} - \frac{2}{8} = -\frac{3}{8}$$

$$v = -2.67 \text{ cm}$$

Since, $v = -2.67 \text{ cm}$ and the second lens is 16 cm away, the image distance for lens B:

$$u' = 16 - 2.67 = 13.33 \text{ cm}$$

$$\text{Again, using lens formula: } = \frac{1}{v'} - \frac{1}{13.33} = \frac{1}{-8}$$

$$\frac{1}{v'} = \frac{1}{-8} + \frac{1}{13.33} = -0.2$$

Position of the final image: 5 cm to the left of lens B.

Nature of the image: Virtual and upright.

So, the image forms at -5.0 cm .

20. Given: $h = 6.63 \times 10^{-34} \text{ J}\cdot\text{s}$
 $c = 3.0 \times 10^8 \text{ m/s}$

$$\lambda = 400 \text{ nm} = 400 \times 10^{-9} \text{ m}$$

$$\phi = 3.0 \times 10^{-19} \text{ J}$$

Using the photoelectric equation:

$$KE_{\max} = hf - \phi$$

$$KE_{\max} = hc/\lambda - \phi$$

$$KE_{\max} = (6.63 \times 10^{-34}) \frac{(3.0 \times 10^8)}{400 \times 10^{-9}} - 3.0 \times 10^{-19}$$

$$KE_{\max} = 4.97 \times 10^{-19} - 3.0 \times 10^{-19} = 1.97 \times 10^{-19} \text{ J}$$

Using $KE = \frac{1}{2}mv^2$, solving for v :

$$v = \sqrt{2KE/m_e}$$

$$v = \sqrt{2 \left(\frac{1.97 \times 10^{-19}}{9.11 \times 10^{-31}} \right)}$$

$$v \approx 6.6 \times 10^5 \text{ m/s}$$

21. Threshold voltage of a silicon diode is 0.7 V.

Given: Using Ohm's Law:

$$V = V_d + IR$$

$$V = 0.7 + (15 \times 10^{-3} \times 1000)$$

$$V = 0.7 + 15 = 15.7 \text{ V}$$

SECTION - C

22. (a) For a cell with EMF E and internal resistance r :

$$V = E - Ir$$

Substituting $I = \frac{V}{R}$

Rearranging:

$$V \left(1 + \frac{r}{R} \right) = E$$

$$V = \frac{ER}{(R+r)}$$

- (b) The graph showing the variation of terminal voltage V with current I .

Variation of Terminal Voltage with Current

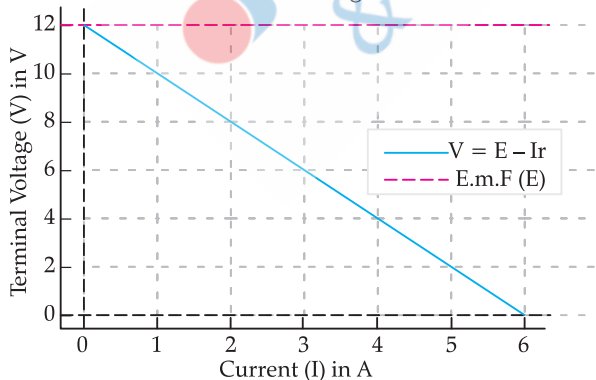

The y -intercept of the graph gives the emf (E) of the cell.

The slope of the graph ($-r$) gives the internal resistance (r) of the cell.

23. (a) (i) The graphical ray diagram illustrating the directions of velocity, electric field and magnetic field

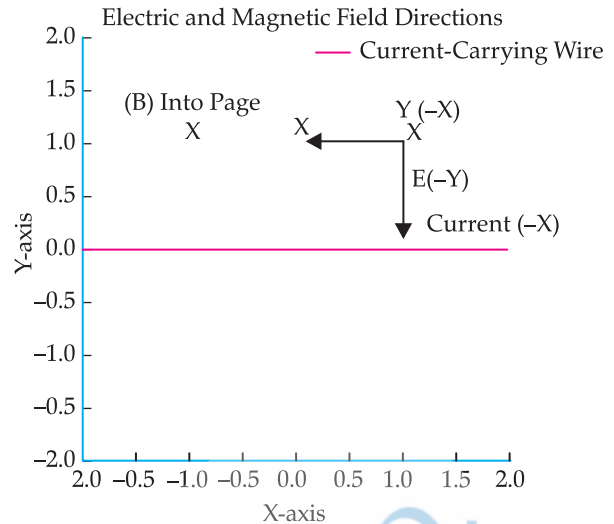

- (ii) The forces acting on the charged particle include:

- **Electric Force:** $F_E = qE$, where q is the charge of the particle.
- **Magnetic Force (Lorentz Force):** $F_B = q(\vec{v} \times \vec{B})$, where B is the magnetic field due to the conductor.
- **Gravitational Force:** $F_G = mg$, where m is the mass of the particle.

- (iii) The magnetic field due to the conductor at a distance d is given by:

$$B = \mu_0 \frac{I}{2\pi d}$$

The Lorentz force acting on the charged particle:

$$qv_0B = qE$$

$$\frac{V_0 \mu_0 I}{2\pi d} = E$$

Solving for V_0 :

$$V_0 = \frac{2\pi d E}{\mu_0 I}$$

OR

- (b) A long, straight wire produces a magnetic field given by:

$$B = \frac{\mu_0 I}{2\pi r}$$

Magnetic field due to wire along X -axis where $y = 0$ and the point $P(X, Y)$ is at a perpendicular distance Y from this wire.

Using the right-hand rule, the magnetic field at $P(X, Y)$ due to this wire is into the plane (negative Z -direction).

Thus, the magnitude is: $B_1 = \frac{\mu_0 I}{2\pi Y}$ and its direction is

into the plane (negative Z -direction).

Magnetic field due to wire along Y -axis where $x = 0$ and the point $P(X, Y)$ is at a perpendicular distance X from this wire.

Using the right-hand rule, the magnetic field at $P(X, Y)$ due to this wire is also into the plane (negative Z -direction).

Thus, the magnitude is: $B_2 = \frac{\mu_0 I}{2\pi X}$ and its direction

is also into the plane (negative Z-direction).

Net magnetic field at $P(X, Y)$:

$$B_{\text{net}} = B_1 + B_2 = \mu_0 I / 2\pi Y + \mu_0 I / 2\pi X$$

$$B_{\text{net}} = \frac{\mu_0 I}{2\pi} \left(\frac{1}{X} + \frac{1}{Y} \right)$$

And direction of net magnetic field is into the plane (negative Z-direction).

24. (a) Lenz's Law states that the direction of the induced electromotive force (EMF) and the resulting current in a conductor is always such that it opposes the change in magnetic flux that caused it.

Mathematically, Lenz's Law is expressed as:

$$\varepsilon = \frac{-d\Phi_B}{dt}$$

where, ε is the induced EMF, Φ_B is the magnetic flux. The negative sign indicates opposition to the change in flux.

- (b) (i) The given machine is a DC generator (Dynamo).
(ii) P – Slip Rings (or Split Rings in the case of a DC generator).
Q – Carbon Brushes.
R – Armature (Rotating Coil).
- (iii) The polarities of the magnetic poles: the upper pole is North (N) and the lower pole is South (S).
(The polarity is determined based on the direction of induced current using Fleming's right-hand rule.)
- (iv) The ways of increasing the output voltage.
1. Increasing the speed of rotation of the armature.
 2. Using stronger magnets (to increase the magnetic field strength).

25. (a) In an electromagnetic wave, the electric field (E) and magnetic field (B) are always perpendicular to each other and to the direction of wave propagation. Given that the wave is propagating in the north direction and the electric field (E) oscillates up and down (which means along the vertical direction), the magnetic field (B) must be perpendicular to both. This means the magnetic field will be in the east-west direction.

- (b) The wavelengths of radio waves and microwaves are longer than those of visible light, which are detectable by human eyes.
- (c) Main uses in human life:
- Infrared waves: Used in night vision cameras, remote controls, thermal imaging and medical treatments.
 - Gamma rays: Used in cancer treatment (radiotherapy), sterilisation of medical equipment and nuclear industry applications.

26. (a) When a parallel beam of light enters water obliquely, it bends towards the normal due to refraction. The width of the beam decreases as the rays converge in the denser medium (water).

- (b) A straw appears bent at the water surface due to refraction. Light from the submerged part bends away from the normal when moving from water to air. The brain perceives these refracted rays as coming from a different position, making the straw appear displaced and bent.

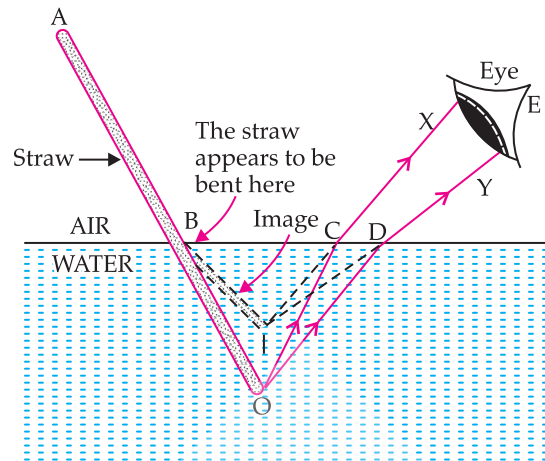

- (c) Optical fibres use total internal reflection (TIR) to transmit light. When light enters at a specific angle, it reflects repeatedly within the fibre's core without escaping, allowing efficient signal transmission over long distances.

Basic operation of an optical fiber.

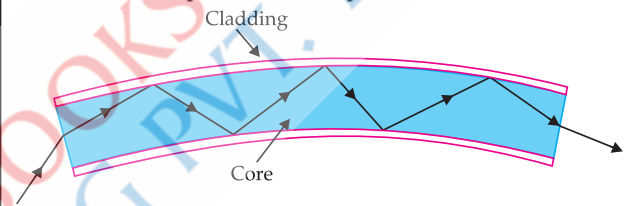

27. (a) Variation of Binding Energy per Nucleon with Mass Number

- The binding energy per nucleon (BE/A) first increases with mass number, reaching a peak around iron ($Fe-56$), and then gradually decreases for heavier nuclei.
- The curve shows a maximum for elements like iron and nickel, indicating their high stability.

Significance of the Binding Energy Curve:

- It explains why lighter elements undergo fusion to become more stable.
 - It explains why heavier elements undergo fission to release energy.
 - It helps in understanding nuclear stability and energy release in nuclear reactions.
- (b) (i) When two nuclei with lower binding energy per nucleon form a nucleus with higher binding energy per nucleon, it is a fusion reaction.
- (ii) Since, the final nucleus has more binding energy per nucleon, the total mass decreases, and energy is produced according to Einstein's equation $E = mc^2$.
- (iii) The process produces energy because the final nucleus is more stable (has higher binding energy per nucleon), and the excess energy is released in the form of heat and radiation. This is why nuclear fusion powers stars.

28. (a) In an n -type semiconductor, the majority carriers are electrons, and the minority carriers are holes and in p -type semiconductor, the majority carriers are holes, and the minority carriers are electrons.

(b) In forward bias, the p -side is connected to the positive terminal and the n -side to the negative terminal of a battery.

- Electrons from the n -side move towards the p -side, and holes from the p -side move towards the n -side.
- This movement reduces the depletion region, allowing current to flow.

(c) From the graph, At $V_1 = -0.6$ V, the reverse current (I_1) is approximately $2 \mu\text{A}$ and at $V_2 = -0.8$ V, the reverse current (I_2) is approximately $2.2 \mu\text{A}$.

Using the formula for dynamic resistance:

$$r_d = \frac{\Delta V}{\Delta I} = \frac{V_2 - V_1}{I_2 - I_1}$$

$$r_d = -\frac{-0.8\text{V} - (-0.6\text{V})}{(2.2 - 2.0) \times 10^{-6}\text{A}}$$

$$r_d = -\frac{0.2\text{V}}{0.2} \times 10^6\text{A}$$

$$r_d = 1\text{ M}\Omega$$

So, the estimated dynamic resistance at $V = -0.6$ V is $1\text{ M}\Omega$ (1 Mega-ohm).

SECTION - D

29. (i) Option (C) is correct.

Explanation: Electric Field in a Parallel Plate Capacitor:

The initial electric field is $E = \frac{V}{d}$

If the plate separation doubles ($2d$) and the applied voltage is halved ($\frac{V}{2}$), the new field is:

$$E' = \left(\frac{\frac{V}{2}}{2d}\right) = \frac{E}{4}$$

So, the new electric field is $\frac{E}{4}$

(ii) Option (D) is correct.

Explanation: To maintain a constant electric field (E) between the plates of a capacitor, the potential difference (V) should be:

$$V = E \cdot d$$

Since, E is constant and d varies, V must be directly proportional to d . This means the graph of V vs. d should be a straight line passing through the origin with a positive slope.

(iii) Option (C) is correct.

Explanation: The electric field between two capacitor plates is uniform. If one plate is at a positive potential and the other at a lower potential, the electric field should remain constant between them. The correct graph should show a constant value of E between the plates without any variation along MN .

(iv) Option (A) is correct.

Explanation: The total potential difference between the third and first plate is:

$$V = d(E_1 + E_2)$$

OR

Option (C) is correct.

Explanation: When a material with a dielectric constant K is introduced into a parallel plate capacitor with initial capacitance C , the new capacitance becomes:

$$C' = KC$$

30. (i) Option (B) is correct.

Explanation: If two metals have different work functions, their straight line graphs are parallel to each other

(ii) Option (C) is correct.

Explanation: From graph, slope (m) = h/e

Then, $h = e \cdot m$

(iii) Option (A) is correct.

Explanation: From graph, intercept on v -axis is v_0 and intercept on v_0 -axis is $h\nu_0/e$

So, $(v_0, \frac{h\nu_0}{e})$

OR

Option (B) is correct.

Explanation: Wave number (k) $i = \frac{2\pi}{\lambda}$. When λ is doubled, k becomes half.

Frequency (f) = $\frac{c}{\lambda}$. When λ is doubled, f becomes half.

So, $(\frac{1}{2}, \frac{1}{2})$

(iv) Option (D) is correct.

Explanation: Given: $p = 5.0 \times 10^{-29}$ kg·m/s and $h = 6.626 \times 10^{-34}$ Js

Since, $p = \frac{h}{\lambda}$

$$\lambda = \frac{h}{p} = \frac{6.63 \times 10^{-34}}{5.0 \times 10^{-29}}$$

$$\lambda = 1.33 \times 10^{-5}\text{ m} = 13.3\ \mu\text{m}$$

SECTION - E

31. (a) (i) Since, sphere A is initially at potential V , its

charge is: $Q_A = \frac{V_r}{k}$

where, $k = 9 \times 10^9 \text{ Nm}^2 \text{ C}^{-2}$

The outer shell B is initially uncharged, so its charge $Q_B = 0$.

When A and B are connected by a thin wire, charge redistributes such that both reach the same final potential V_f .

The potential of a conducting sphere of radius r with charge Q_A is:

$$V_A = \frac{kQ'_A}{r}$$

The potential of the outer shell B with charge Q'_B is:

$$V_A = \frac{kQ'_B}{R}$$

Since, they are connected, $V_A = V_B = V_f$ and charge is conserved:

$$Q'_A = Q'_B = Q_A$$

Substituting for potentials:

$$\frac{kQ'_A}{r} = \frac{kQ'_B}{R} = V_f$$

Solving for Q'_A and Q'_B : $Q'_A = \frac{V_f r}{k}$ and $Q'_B = \frac{V_f R}{k}$

Using charge conservation:

$$\frac{V_f r}{k} + \frac{V_f R}{k} = \frac{V_f R}{k}$$

$$V_f(r + R) = V_f R$$

$$V_f = \frac{V_f R}{(r + R)}$$

(ii) Characteristics of Equipotential Surfaces:

(a) Perpendicular to the Electric Field: Equipotential surfaces are always perpendicular to the direction of the electric field at every point.

(b) No Work Done in Moving a Charge: Since the potential is the same at all points on an equipotential surface, no work is required to move a charge along it.

Given, $E = 50 \text{ N/C}$ along the $+x$ -axis, $V(0, 0) = 220 \text{ V}$,

Since, the field is along the $+x$ -axis, the potential changes only along the x -direction, and there is no potential change along the y -direction.

The potential difference is given by:

$$V = V_0 - E \cdot d$$

From $(0, 0)$ to $(4 \text{ m}, 3 \text{ m})$, the movement in the x -direction is 4 m , so:

$$V(4, 3) = 220 \text{ V} - (50 \times 4)$$

$$V(4, 3) = 220 - 200 = 20 \text{ V}$$

Thus, the potential at $(4 \text{ m}, 3 \text{ m})$ is 20 V .

OR

(b) (i) Difference Between an Open Surface and a Closed Surface

1. Open Surface:

- An open surface has boundaries.
- **Examples:** A hemisphere, a disk, or a sheet of paper.
- Flux calculations through open surfaces consider the flow passing through its boundaries.

2. Closed Surface:

- A closed surface is completely enclosed, meaning it has no boundaries.
- **Examples:** A sphere, a cube, or a closed cylinder.
- A closed surface is useful in Gauss's theorem for calculating flux in vector fields.

Elementary Surface Vector dS for a Spherical Surface:

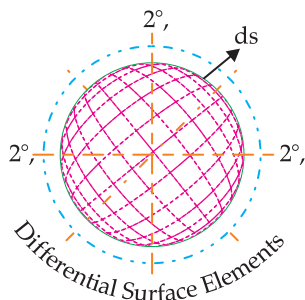

(ii) **Electric flux (Φ_E):** It is the total number of electric field lines passing through a surface. It is given by:

$$\Phi_E = \oint_S E \cdot dA$$

where E is the electric field and dA is the surface element.

Significance of a Gaussian surface:

A Gaussian surface is an imaginary closed surface used in Gauss's law:

$$\oint_S E \cdot dA = \frac{q_{enc}}{\epsilon_0}$$

- It simplifies electric field calculations for symmetric charge distributions.
- It considers only the charge enclosed within the surface.

External charge does not contribute to total flux because:

- An external charge produces equal field lines entering and leaving the surface, resulting in zero net flux.
- Gauss's law states that only enclosed charge affects the total flux.

(iii) Given, charges inside the small spherical shell S_1 :

$$q_1 = -3\mu\text{C}, q_2 = -2\mu\text{C}, q_3 = 9\mu\text{C}$$

Charge Q is placed between the two shells.

The electric flux through S_2 is four times the flux through S_1 .

According to Gauss's law: $\Phi = \frac{Q_{enc}}{\epsilon_0}$

The total charge enclosed by S_1 :

$$Q_{enc, S_1} = (-3 + (-2) + 9)\mu\text{C}$$

$$Q_{enc, S_1} = 4\mu\text{C}$$

$$\Phi_{S_1} = \frac{4\mu\text{C}}{\epsilon_0}$$

Flux through S_2 :

$$\Phi_{S_2} = 4\Phi_{S_1}$$

Substituting Φ_{S_1}

$$Q_{enc, S_2} \frac{1}{\epsilon_0} = 4 \times \frac{4\mu\text{C}}{\epsilon_0}$$

$$Q_{enc, S_2} = 16\mu\text{C}$$

Since, the charge enclosed by S_2 includes both the charge inside S_1 and the additional charge Q :

$$Q_{enc, S_2} = Q_{enc, S_1} + Q$$

$$16\mu\text{C} = 4\mu\text{C} + Q$$

$$Q = 12\mu\text{C}$$

So, the charge Q must be $12\mu\text{C}$ to satisfy the given flux condition.

32. (a) (i) Force between two long straight parallel conductors carrying current in the same direction:

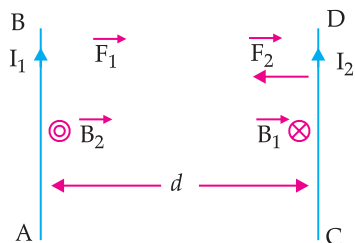

Two wires AB and CD carry currents I_1 and I_2 respectively in the same direction.

Distance between them is d .

Due to I_1 current in AB,

$$\text{Magnetic field at any point on CD is } B_1 = \frac{\mu_0}{4\pi} \times \frac{2I_1}{d}$$

$$\text{Force on unit length of CD is } F_1 = \frac{BIL}{L} = B_1 \times I_2 \times 1$$

$$= \frac{\mu_0}{4\pi} \times \frac{2I_1I_2}{d}, \text{ acting towards AB (applying}$$

Fleming's left hand rule)

Similarly,

Due to I_2 current in CD,

$$\text{Magnetic field at any point on AB is } B_2 = \frac{\mu_0}{4\pi} \times \frac{2I_2}{d}$$

$$\text{Force on unit length of AB is } F_2 = \frac{BIL}{L} = B_2 \times I_1 \times 1 =$$

$$\frac{\mu_0}{4\pi} \times \frac{2I_1I_2}{d}, \text{ acting towards CD (applying Fleming's}$$

left hand rule)

So, the magnitudes of F_1 and F_2 are same and oppositely directed. So, the forces are attractive.

Definition of 1 ampere:

If $I_1 = I_2 = 1$ ampere and $d = 1$ m,

$$\text{Then, } F = \frac{\mu_0}{4\pi} \times \frac{2I_1I_2}{d} \\ = 2 \times 10^{-7} \text{ N}$$

So, 1 A may be defined as,

The amount of steady current which, when maintained in each of the two very long, straight, parallel conductors of negligible cross-section, and placed one metre apart in vacuum, would exert on each of these conductors a force equal to 2×10^{-7} N per metre of length.

- (ii) The magnetic force is always perpendicular to the velocity v because of the cross product.

Since, displacement dr is in the direction of v , we have:

$$dW = q(v \times B) \cdot v$$

Using the vector identity $(A \times B) \cdot C = 0$ if $C = A$ we get: $dW = 0$

So, the work done per infinitesimal displacement is always zero; the total work done by the magnetic force on the charge is also zero, regardless of how the charge moves. The magnetic field only changes the direction of motion of the charge, not its speed or kinetic energy.

- (iii) A charged particle follows a helical trajectory in a uniform magnetic field (B) if-

- (1) The external magnetic field must be constant in magnitude and direction.
- (2) The particle's velocity (v) must have both perpendicular component (v_{\perp}) that causes circular motion around field lines and parallel component (v_{\parallel}) that causes uniform motion along the field.
- (3) The combination of circular motion and linear motion results in a helix.
- (4) The motion remains helical as long as no other external forces (like electric fields) act on the particle.

OR

- (b) (i) A current-carrying loop behaves as a magnetic dipole because it creates a magnetic field similar to that of a bar magnet, has a well-defined magnetic dipole moment, and experiences torque in an external field. Hence, it can be considered as a magnetic dipole placed along its axis.

- (ii) Let a coil have current I , number of turns N and area of each loop A

The magnetic dipole moment for a single loop is given by: $M = IA_n$

where, A is the area enclosed by the loop ($A = \pi R^2$ for a circular coil) and n is the unit normal vector to the plane of the loop (direction given by the right-hand rule).

If the coil has N turns, the total magnetic dipole moment is: $M = NIA_n$

The direction of M is perpendicular to the plane of the coil and determined by the right-hand rule.

- (iii) A current-carrying coil placed in an external uniform magnetic field experiences torque but no net force if the field is uniform. The force on a current-carrying element dl of the coil is given by:

$$dF = Idl \times B$$

For a closed loop, the forces on opposite sides of the loop may be equal and opposite, cancelling out in a uniform field. Thus, the net force on the coil is zero, but a torque exists.

The torque on a current loop in an external magnetic field is given by:

$$T = m \times B$$

where, m is the magnetic dipole moment of the coil $m = NIA_n$.

The torque tries to align the coil's magnetic moment with the external magnetic field B and the coil reaches stable equilibrium when the torque is zero, i.e., $m \times B = 0$. This happens when m is parallel to B , meaning the plane of the coil is perpendicular to the external field. The potential energy of the system in an external field is:

$$U = -m \cdot B = -mB \cos \theta$$

The minimum potential energy (stable equilibrium) occurs at $\theta = 0^\circ$.

The magnetic flux through the coil is:

$$\Phi = \int B_{\text{total}} \cdot dA$$

where, B_{total} is the sum of the external field B and the field due to the coil. The field due to the coil is along its magnetic moment direction. When the coil aligns with B , its own field adds constructively to the external field, making the total field maximum.

$$\Phi_{\text{max}} = (B_{\text{ext}} + B_{\text{coil}})A$$

Thus, in the stable equilibrium position where m is parallel to B , the flux through the coil is maximised.

33. (a) (i) Given, a thin pencil of length $\frac{f}{4}$ is placed

along the principal axis of a mirror of focal length f .

The image of the pencil is real, enlarged means the mirror must be a concave mirror with the object placed between f and $2f$ to ensure that its image forms beyond $2f$ and just touches suggests that the image coincides with one end of the pencil.

Let the object be placed at distance u from the mirror, forming an image at v . The magnification is given by: $m = \frac{-v}{u}$.

We assume the object is placed at $u = 1.5f$ (or $\frac{3f}{2}$),

and it is an enlarged and real image.

By the mirror formula

$$\frac{1}{f} = \frac{1}{u} + \frac{1}{v}$$

$$\text{Substituting } u = \frac{3f}{2}$$

$$\frac{1}{f} = \frac{1}{\frac{3f}{2}} + \frac{1}{v}$$

$$\frac{1}{f} - \frac{2}{3f} = \frac{1}{v}$$

$$\frac{(3-2)}{3f} = \frac{1}{v}$$

$$\frac{1}{3f} = \frac{1}{v}$$

$$v = 3f$$

$$\text{Magnification: } m = \frac{-v}{u} = \frac{-3f}{\frac{3f}{2}} = -2$$

Since, magnification is negative, the image is inverted and twice the size of the object.

- (ii) Given, angle of incidence $i = 45^\circ$, angle of deviation: $\delta = 15^\circ$, angle of prism: $A = 30^\circ$

Since, by prism formula: $\delta = i + e - A$

Substituting the given values:

$$15^\circ = 45^\circ + e - 30^\circ$$

$$e = 0^\circ$$

Since, the angle of emergence (e) is zero, the emergent ray is normal to the face AC.

For refractive index by using Snell's law at face AB:

$$n_1 \sin i = n_2 \sin r$$

Since, the incident ray is in air, $n_1 = 1$, and let $n_2 = n$ be the refractive index of the prism material. The angle of refraction at face AB is denoted by r .

$$\sin 45^\circ = n \sin r$$

$$\frac{\sqrt{2}}{2} = n \sin r \quad \dots(i)$$

Using the prism angle formula: $r + r' = A$

$$r + r' = 30^\circ$$

Since, the emergent ray is normal to AC, $r' = 0^\circ$
So, $r = 30^\circ$

Now, substituting $r = 30^\circ$ in Eq. (i)

$$\frac{\sqrt{2}}{2} = n \sin 30^\circ$$

$$\frac{\sqrt{2}}{2} = n \times \frac{1}{2}$$

$$n = \sqrt{2} \approx 1.414$$

OR

- (b) (i) Given,

Wavelengths: $\lambda_1 = 600 \text{ nm} = 600 \times 10^{-9} \text{ m}$ and $\lambda_2 = 480 \text{ nm} = 480 \times 10^{-9} \text{ m}$

Distance between slits: $d = 1.0 \text{ mm} = 1.0 \times 10^{-3} \text{ m}$

Distance from slits to screen: $L = 1.0 \text{ m}$

(1) Distance of the third bright fringe for $\lambda_1 = 600 \text{ nm}$

$$\text{The fringe width } y = \frac{m\lambda L}{d}$$

For the third bright fringe ($m = 3$):

$$y_3 = \frac{3 \times (600 \times 10^{-9}) \times 1}{1.0 \times 10^{-3}}$$

$$y_3 = \frac{3 \times 600 \times 10^{-9}}{10^{-3}}$$

$$y_3 = \frac{1800 \times 10^{-9}}{10^{-3}} = 1.8 \text{ mm}$$

- (2) Least distance from the central maximum where bright fringes coincide:

Bright fringes from both wavelengths will coincide at a position where the order numbers m_1 and m_2 satisfy:

$$m_1 \lambda_1 = m_2 \lambda_2$$

The LCM of the wavelengths gives the least position where both fringes coincide, i.e., LCM (600, 480) = 2400 nm = $2.4 \times 10^{-6} \text{ m}$.

Now, the fringe distance for this position:

$$y = \frac{2.4 \times 10^{-6} \times 1}{10^{-3}}$$

$$y = \frac{2.4 \times 10^{-6} \times 1}{10^{-3}} = 2.4 \text{ mm}$$

- (ii) (1) Graph of Intensity vs. Angle of Diffraction

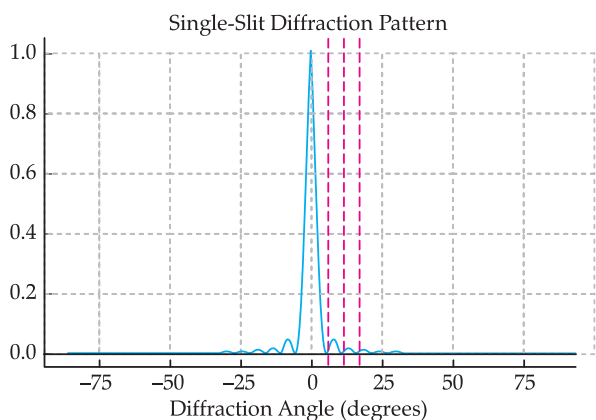

The dark fringes (minima) in a single-slit diffraction occur at angles where destructive interference happens. These angles are given by:

$$a \sin \theta = m \lambda$$

where: a = slit width, θ = wavelength of light, θ = diffraction angle, $m = 1, 2, 3, \dots$ (integer, not including 0, since $m = 0$ corresponds to the central maximum)

(2) Difference Between Diffraction of Light and Sound Waves:

Feature	Light Waves	Sound Waves
Wavelength	Very small ($\sim 10^{-7}$ m)	Larger ($\sim 10^{-3}$ to metres)
Diffraction Observability	Requires very narrow slits/gaps	Easily observed around obstacles
Practical Example	Light bending around a sharp edge	Sound heard around corners
Extent of Diffraction	Less noticeable due to small wavelength	More noticeable due to larger wavelength

Thus, sound waves diffract more easily around obstacles compared to light waves due to their longer wavelengths.

Outside Delhi Set-2

55/2/2

SECTION – A

1. Option (D) is correct.

Explanation:

A hollow conducting sphere placed at P will create an induced charge distribution on its surface. This redistribution of charge ensures that the electric field inside the hollow region of the conductor is zero.

Since P is inside the hollow sphere, the electric field at P must be zero.

2. Option (A) is correct.

Explanation: Given that:

EMF of the battery, $E = 12$ V

Internal resistance, $r = 0.5 \Omega$

External resistance, $R = 9.5 \Omega$

When the key is open, no current flows in the circuit.

$$V_{\text{open}} = E = 12 \text{ V}$$

When the key is closed, current flows in the circuit.

The total resistance in the circuit is:

$$R_{\text{total}} = R + r = 9.5 + 0.5 = 10 \Omega$$

The current flowing through the circuit is given by Ohm's law:

$$I = \frac{E}{R_{\text{total}}} = \frac{12}{10} = 1.2 \text{ A}$$

The potential difference across the battery terminals when current is flowing is:

$$V_{\text{closed}} = E - Ir$$

$$V_{\text{closed}} = 12 - (1.2 \times 0.5) = 12 - 0.6 = 11.4 \text{ V}$$

$$\frac{V_{\text{open}}}{V_{\text{closed}}} = \frac{12}{11.4} = \frac{20}{19} = 1.05$$

4. Option (D) is correct.

Explanation: Diamagnetic substances have **no permanent magnetic dipoles**. Instead, when placed

in an external magnetic field, they develop **induced magnetic dipoles** in the **opposite direction** to the external field. This means it is **repelled** by both the **north** and **south** poles of a magnet.

5. Option (A) is correct.

Explanation: Given data:

Inner solenoid:

Radius = r_1

Number of turns per unit length = n_1

Length = l (assuming both solenoids have the same length)

Outer solenoid:

Radius = r_2 where $r_2 > r_1$

Number of turns per unit length = n_2

The self-inductance of a solenoid is given by:

$$L = \mu_0 n^2 A l$$

For the **inner solenoid**, the cross-sectional area is $A_1 = \pi r_1^2$

$$\text{so, } L_1 = \mu_0 n_1^2 \pi r_1^2 l$$

Mutual inductance is given by:

$$M = \mu_0 n_1 n_2 A_{\text{common}} l$$

Since, the inner solenoid is **completely enclosed by the outer solenoid**, the common cross-sectional area is the area of the **inner solenoid**, i.e., $A_{\text{common}} = \pi r_1^2$.

Thus, the mutual inductance is:

$$M = \mu_0 n_1 n_2 \pi r_1^2 l$$

Required ratio

$$\frac{L_1}{M} = \frac{\mu_0 n_1^2 \pi r_1^2 l}{\mu_0 n_1 n_2 \pi r_1^2 l}$$

$$\frac{L_1}{M} = \frac{n_1}{n_2}$$

7. Option (C) is correct.

Explanation: Given data:

Number of turns: $N = 100$ N

Area of each turn: $A = 0.1 \text{ m}^2$

Rotation frequency: $f = 0.5$ rotations per second

Magnetic field strength: $B = 0.02 \text{ T}$

The maximum EMF induced in a rotating coil is given by:

$$E_{\text{max}} = NBA\omega$$

where:

$\omega = 2\pi f$ is the angular velocity of the coil.

$$\omega = 2\pi f = 2\pi \times 0.5 = \pi \text{ rad/s}$$

$$E_{\text{max}} = (100) \times (0.02) \times (0.1) \times (\pi)$$

$$E_{\text{max}} = 100 \times 0.002 \times \pi$$

$$E_{\text{max}} = 0.2 \pi$$

$$E_{\text{max}} = 0.2 \times 3.14 = 0.628 \text{ V}$$

$$E_{\text{max}} = 0.63 \text{ V}$$

9. Option (D) is correct.

Explanation: The focal length of a concave mirror does not depend on the refractive index of the surrounding medium because the mirror reflection follows the laws of reflection, which remain unchanged regardless of the medium.

SECTION – B

18. Consider a plane wavefront incident from medium 1 (refractive index n_1 , speed of light v_1) onto a plane boundary with medium 2 (refractive index n_2 , speed of light v_2).

The incident wavefront approaches the boundary at an angle of incidence i .

The refracted wavefront moves in medium 2 at an angle of refraction r .

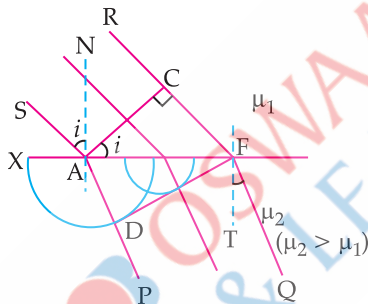

Applying Huygens' Principle:

Wavefront in Medium 1:

Consider a wavefront AC moving towards the interface.

Each point on AC acts as a secondary source, emitting wavelets.

Wavefront in Medium 2:

When point A reaches the interface, it immediately starts emitting secondary wavelets in the second medium.

After time t , point C reaches the interface at point F, and secondary wavelets in the second medium form the new wavefront DF.

Derivation of Snell's Law

From the geometry of the wavefront:

Distance travelled by the incident wavefront in medium 1:

$$AC = v_1 t$$

Distance travelled by the refracted wavefront in

medium 2:

$$DF = v_2 t$$

The incident and refracted wavefronts make angles i and r with the interface, so:

$$\sin i = \frac{AC}{AF} = \frac{v_1 t}{AF} \quad \dots(i)$$

$$\sin r = \frac{AD}{AF} = \frac{v_2 t}{AF} \quad \dots(ii)$$

On solving equation (i) and (ii)

$$\frac{\sin i}{\sin r} = \frac{v_1}{v_2}$$

Since, the refractive index is defined as $n = \frac{c}{v}$, where

c is the speed of light in a vacuum:

$$\frac{v_1}{v_2} = \frac{n_2}{n_1}$$

Thus, we get Snell's law:

$$n_1 \sin i = n_2 \sin r$$

19. Step 1: First Lens (Lens A at 50.0 cm)

Focal length: $f_A = 10.0 \text{ cm}$

Object distance: $u_A = 20.0 - 50.0 = -30.0 \text{ cm}$ (since, the object is before the lens, it is negative)

Using the lens formula:

$$\frac{1}{v_A} = \frac{1}{f_A} + \frac{1}{u_A}$$

$$\frac{1}{v_A} = \frac{1}{10} - \frac{1}{30}$$

$$\frac{1}{v_A} = \frac{(3-1)}{30} = \frac{2}{30} = \frac{1}{15}$$

$$v_A = 15 \text{ cm}$$

So, the image formed by Lens A is at $50 + 15 = 65 \text{ cm}$ on the optical bench.

Step 2: Second Lens (Lens B at 70.0 cm)

The image formed by Lens A (at 65 cm) acts as the object for Lens B.

Focal length: $f_B = 10.0 \text{ cm}$

Object distance: $u_B = 65 - 70 = -5.0 \text{ cm}$ (negative since, it's before the lens)

Using the lens formula:

$$\frac{1}{v_B} = \frac{1}{f_B} + \frac{1}{u_B}$$

$$\frac{1}{v_B} = \frac{1}{10} - \frac{1}{5}$$

$$\frac{1}{v_B} = \frac{(1-2)}{10} = \frac{-1}{10}$$

$$v_B = -10 \text{ cm}$$

The negative v_B means the final image is virtual and located 10 cm before Lens B.

Lens B is at 70 cm, so the final image is at:

$$70 - 10 = 60 \text{ cm}$$

The image is upright and magnified.

20. Given data:

Work function of the metal: $\phi = 2.0 \text{ eV}$

Photon energy in Case 1: $E_1 = 2.5 \text{ eV}$

Photon energy in Case 2: $E_2 = 4.5 \text{ eV}$

Using the photoelectric equation:

$$K_{\max} = E - \phi$$

Maximum Kinetic Energy in Both Cases

Case 1:

$$K_1 = E_1 - \phi = 2.5 - 2.0 = 0.5 \text{ eV}$$

Case 2:

$$K_2 = E_2 - \phi = 4.5 - 2.0 = 2.5 \text{ eV}$$

The maximum kinetic energy is related to the electron speed using:

$$K = \frac{1}{2} mv^2$$

So,
$$v = \sqrt{\frac{2K}{m}}$$

Taking the ratio of speeds in both cases:

$$\frac{v_1}{v_2} = \sqrt{\frac{K_1}{K_2}}$$

Substituting values:
$$\frac{v_1}{v_2} = \sqrt{\frac{0.5}{2.5}} = \sqrt{\frac{1}{5}}$$

$$\frac{v_1}{v_2} = \frac{1}{\sqrt{5}}$$

$$v_1 : v_2 = 1 : \sqrt{5}$$

SECTION – C

22. (a) The resistivity of a conductor is a measure of how strongly the material opposes the flow of electric current. It is defined as the resistance of a unit-length conductor with a unit cross-sectional area. Mathematically, resistivity (ρ) is given by:

$$\rho = \frac{RA}{L}$$

where all alphabets are in their usual meanings.

Dependence of Resistivity on Temperature:

The resistivity of a conductor increases with temperature. This happens because, as temperature increases:

- The thermal vibrations of atoms increase.
- These vibrations cause more frequent collisions between free electrons and atoms.
- This reduces electron mobility, leading to higher resistivity.
- The temperature dependence of resistivity for most metals is given by the linear relation:

$$\rho(T) = \rho_0[1 + \alpha(T - T_0)]$$

24. Difference Between Peak Value and RMS Value of AC

Parameter	Peak Value (I_0)	Root Mean Square (RMS) Value (I_{rms})
Definition	The maximum value of AC during a cycle.	The effective value of AC that produces the same heating effect as DC.
Symbol	I_0	I_{rms} and $I_{\text{rms}} = \frac{I_0}{\sqrt{2}}$
Value	Always greater than I_{rms}	70.7% of I_0 .
Significance	Represents that highest instantaneous	Represents the useful power output.

- **Graph: Resistivity of Copper vs. Temperature**

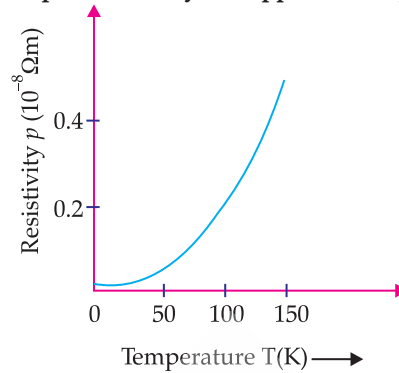

- (b) The total voltage provided by a battery is given by:

$$V = E - Ir$$

where all alphabets are in their usual meanings.

From Ohm's law:

$$I = \frac{E}{(R + r)}$$

where R is the external resistance.

- (i) For a **low-voltage battery**, E is small. To **obtain a high current**, r must be **very small** so that most of the voltage is available to the external circuit. If r were large, a significant part of the battery's voltage would drop inside the battery itself, reducing the current in the external circuit. Thus, a **low internal resistance** ensures that **maximum power is delivered to the external load** instead of being wasted as heat inside the battery.

Examples: Car batteries, lithium-ion batteries and supercapacitors have very low internal resistance for efficient high-current output.

- (ii) If the battery has a **high emf** (E), but a **large internal resistance** (r), it **limits the current** (I). This prevents excessive current flow, which could otherwise cause overheating, energy loss, or damage to the circuit. A **higher internal resistance ensures a stable and controlled current supply**, making the battery safe for sensitive applications.

Examples: Electrostatic generators (Van deGraaff) and high-voltage power sources use high internal resistance for safety and efficiency.

Derivation of RMS Value of AC

An alternating current (AC) varies sinusoidally as:

$$I = I_0 \sin \omega t$$

where:

I_0 = peak current,

ω = angular frequency,

t = time.

The root mean square (RMS) value of current is given by:

$$I_{\text{rms}} = \sqrt{\frac{1}{T} \int_0^T I^2 dt}$$

where T is the time period of the AC cycle.

Substituting $I = I_0 \sin \omega t$

$$I_{\text{rms}} = \sqrt{\frac{1}{T} \int_0^T I_0^2 \sin^2 \omega t dt}$$

Since, I_0^2 is constant, it can be taken outside the integral:

$$I_{\text{rms}} = \sqrt{\frac{1}{T} \int_0^T I_0^2 \sin^2 \omega t dt}$$

The time-averaged value of $\sin^2 \omega t$ over one full cycle is:

$$\frac{1}{T} \int_0^T \sin^2 \omega t dt = \frac{1}{2}$$

Thus,

$$I_{\text{rms}} = \sqrt{I_0^2 \times \frac{1}{2}}$$

$$I_{\text{rms}} = \frac{I_0}{\sqrt{2}}$$

Final Expression

$$I_{\text{rms}} = \frac{I_0}{\sqrt{2}} \approx 0.707 I_0$$

25. (a) Electromagnetic (EM) waves are generated when an **electric charge accelerates**, causing **changing electric and magnetic fields** that propagate through space.

(b) Given data,

Wave propagation (k) \rightarrow Vertically upward (+z direction).

Electric field (E) \rightarrow West ($-x$ direction).

Find: Magnetic field (B) direction

Using the right-hand rule ($\vec{k} = \vec{E} \times \vec{B}$)

Point fingers of your right hand in the direction of the electric field E (West, $-x$).

Curl your fingers toward the direction of magnetic field B (to be determined).

Your thumb should point in the direction of wave propagation (upward, +z).

To satisfy this condition, B must point south ($-y$).

(c) Wavelength Ranges

Radio Waves:

Shortest wavelength ($\lambda_{\text{radio, min}}$) $\approx 1 \text{ mm} = 10^{-3} \text{ m}$

Gamma Rays:

Longest wavelength ($\lambda_{\text{gamma, max}}$) $\approx 10^{-10} \text{ m}$

$$\text{Ratio} = \frac{\lambda_{\text{radio, min}}}{\lambda_{\text{gamma, max}}} = \frac{10^{-3} \text{ m}}{10^{-10} \text{ m}} = 10^7$$

Outside Delhi Set-3

55/2/3

SECTION – A

1. **Option (A) is correct.**

Explanation: The dipole moment is given by:

$$p = q \cdot (\text{displacement from } -q \text{ to } +q)$$

For diode D_1 , the charges $-q$ and $+q$ are located at $(0, 0)$ and $(a, 0)$, respectively,

$$p_1 = qa \hat{i}$$

For diode D_2 , the charges $-q$ and $+q$ are located at $(0, a)$ and $(a, 2a)$, respectively,

$$p_2 = qa \hat{j}$$

Net dipole moment,

$$p_{\text{net}} = p_1 + p_2 = qa \hat{i} + qa \hat{j}$$

$$p_{\text{net}} = qa(\hat{i} + \hat{j})$$

2. **Option (D) is correct.**

Explanation: $R_{\text{internal}} = 3 \Omega$

$$R_{\text{external}} = 24 \Omega$$

$$R = R_{\text{internal}} + R_{\text{external}} = 3 + 24 = 27 \Omega$$

The current in the circuit,

$$I = \frac{V_{\text{source}}}{27}$$

And, the voltage across 24Ω resistance is,

$$V = I \cdot 24$$

$$\text{For, } I = 2.0 \text{ A, } V = 2 \times 24 = 48 \text{ V}$$

$$\text{For, } I = 0.5 \text{ A, } V = 0.5 \times 24 = 12 \text{ V}$$

Hence, option (D) values match perfectly for ideal ammeter and ideal voltmeter.

4. **Option (B) is correct.**

Explanation: A material that is pushed out of a uniform magnetic field is diamagnetic. Diamagnetic materials develop an induced magnetic moment opposite to the external field, causing a weak repulsion. Examples: bismuth, copper and graphite.

5. **Option (B) is correct.**

Explanation: As the soft iron rod falls, it enhances the magnetic field between the poles of the U-shaped magnet, causing an increase in magnetic flux through the coil. According to Faraday's law, a change in magnetic flux induces an electromotive force (EMF) in the coil. By Lenz's law, the induced current flows in a direction that opposes the increase in flux. To counteract the growing magnetic field, the coil generates its own magnetic field opposite to the change, resulting in an anticlockwise current when viewed from the top.

7. **Option (D) is correct.**

Explanation: Given, $V_p = 20 \text{ V}$

$$N_p = 20 \text{ turns}$$

$$V_s = 120 \text{ V}$$

Using the transformer equation,

$$\frac{V_s}{V_p} = \frac{N_s}{N_p}$$

$$N_S = \frac{20 \times 120}{20} = 120 \text{ turns}$$

We know,
 P to Q \rightarrow 20 turns
 Q to R \rightarrow 40 turns
 R to S \rightarrow 60 turns

So, total turns = 120. Hence, the terminals between which the voltage will be 120 V are P and S.

9. Option (D) is correct.

Explanation: We know, lens maker's formula,

$$\frac{1}{f_{\text{lens}}} = (n-1) \left(\frac{1}{R_1} - \frac{1}{R_2} \right)$$

For plano-convex lens,
 Plane side- $R_1 \rightarrow \infty$
 Curved side- $R_2 = -R$

$$\frac{1}{f_{\text{lens}}} = (n-1) \left(0 - \frac{1}{-R} \right)$$

$$\frac{1}{f_{\text{lens}}} = \frac{(n-1)}{R}$$

Since, the plane surface is silvered, it acts as a plane mirror with an infinite focal length, $f_{\text{mirror}} \rightarrow \infty$.

For a silvered lens, the effective focal length F is given by,

$$\frac{1}{F} = 2 \left(\frac{1}{f_{\text{lens}}} \right) + \frac{1}{f_{\text{mirror}}}$$

$$\frac{1}{F} = 2 \times \frac{(n-1)}{R} + 0$$

$$F = \frac{R}{2(n-1)}$$

SECTION - B

18. Given,

Angular fringe width, $\theta = 0.2^\circ = 0.2 \times \frac{\pi}{180} \text{ rad}$

Wavelength, $\lambda = 500 \text{ nm} = 500 \times 10^{-9} \text{ m}$

So, the separation of slits,

$$d = \frac{\lambda}{\theta}$$

$$d = \frac{500 \times 10^{-9} \times 180}{0.2 \times 3.14}$$

$$d = 0.143 \text{ mm}$$

19. Given,

Focal length of concave lens, $f = -15 \text{ cm}$

Distance of the lens from point O, $u = -10 \text{ cm}$

Using the lens formula,

$$\frac{1}{f} = \frac{1}{v} - \frac{1}{u}$$

$$\frac{1}{v} = \frac{1}{-15} + \frac{1}{10}$$

$$\frac{1}{v} = \frac{(-2+3)}{30}$$

$$\frac{1}{v} = \frac{1}{30}$$

$$v = 30 \text{ cm}$$

Shift in convergence OO' ,

$$OO' = |v - O| = |30 - 10| = 20 \text{ cm}$$

Hence, the magnitude of the shift OO' is 20 cm, and the direction is away from the lens (to the right).

20. Given,

Threshold wavelength, $\lambda_0 = 450 \times 10^{-9} \text{ m}$

Incident wavelength, $\lambda = 250 \times 10^{-9} \text{ m}$

(i) Work function,

$$\phi = \frac{hc}{\lambda_0}$$

$$\phi = \frac{6.63 \times 10^{-34} \times 3 \times 10^8}{450 \times 10^{-9}}$$

$$\phi = 4.42 \times 10^{-19} \text{ J}$$

$$\phi = \frac{4.42 \times 10^{-19}}{1.6 \times 10^{-19}}$$

$$\phi = 2.76 \text{ eV}$$

(ii) Maximum kinetic energy,

$$KE_{\text{max}} = \frac{hc}{\lambda} - \phi$$

$$KE_{\text{max}} = \frac{6.63 \times 10^{-34} \times 3 \times 10^8}{250 \times 10^{-9}} - 4.42 \times 10^{-19}$$

$$KE_{\text{max}} = 7.96 \times 10^{-19} - 4.42 \times 10^{-19}$$

$$KE_{\text{max}} = 3.54 \times 10^{-19} \text{ J}$$

$$KE_{\text{max}} = \frac{3.54 \times 10^{-19}}{1.6 \times 10^{-19}} \text{ eV}$$

$$KE_{\text{max}} = 2.21 \text{ eV}$$

SECTION - C

22. (a) Electrical conductivity (σ) is the ability of a material to conduct electric current. It is the reciprocal of resistivity and is given by,

$$\sigma = \frac{1}{\rho}$$

where ρ is the electrical resistivity of the material.

From Ohm's law,

$$J = \sigma E$$

where, all alphabets are in their usual meanings.

The current density J is given by,

$$J = nev_d$$

Using the drift velocity (v_d) formula now,

$$v_d = \frac{eE\tau}{m}$$

where τ = relaxation time

m = mass of an electron

Now,

$$J = ne \left(\frac{eE\tau}{m} \right)$$

$$J = \frac{ne^2\tau}{m} E$$

Comparing with $J = \sigma E$,

$$\rho = \frac{ne^2\tau}{m}$$

(b) We can write,

$$\rho = \frac{1}{\sigma} = \frac{m}{ne^2\tau}$$

Now, the effects of temperature:

24. (a) In a series LCR circuit, current is same in all three components.

- The voltage across the resistor (V_R) is in phase with the current.
- The voltage across the inductor (V_L) leads the current by 90 degrees.
- The voltage across the capacitor (V_C) lags the current by 90 degrees.

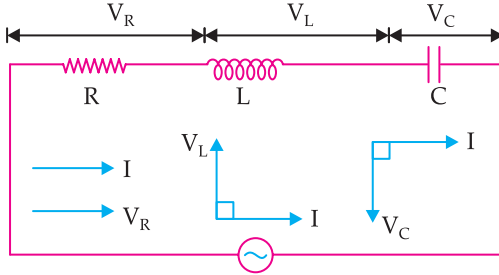

LCR Circuit

Now, the net voltage is given by,

$$V = \sqrt{V_R^2 + (V_L - V_C)^2}$$

$$V = \sqrt{(IR)^2 + (IX_L - IX_C)^2}$$

$$V = I\sqrt{R^2 + (X_L - X_C)^2}$$

The impedance Z is defined as $Z = \frac{V}{I}$. Therefore,

$$Z = \sqrt{R^2 + (X_L - X_C)^2} \quad \left[\because X_L = \omega L, X_C = \frac{1}{\omega C} \right]$$

$$Z = \sqrt{R^2 + \left(\omega L - \frac{1}{\omega C} \right)^2}$$

(b) Resonance in a series LCR circuit occurs when the inductive reactance and capacitive reactance cancel each other, i.e.,

$$X_L = X_C$$

$$\omega L = \frac{1}{\omega C}$$

So, resonant frequency,

$$\omega_0 = \frac{1}{\sqrt{LC}}$$

Resonant frequency in Hertz is,

$$f_0 = \frac{1}{2\pi\sqrt{LC}}$$

- In a conductor, as temperature increases, the number density (n) remains nearly constant.
- The relaxation time τ decreases due to increased collisions between electrons and vibrating ions.
- Since, τ decreases, ρ increases.
Thus, the resistivity of a conductor increases with an increase in temperature.

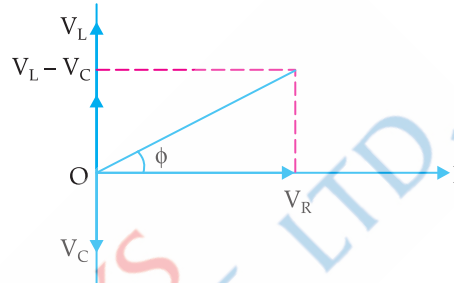

At resonance, $Z = R$, i.e., the circuit is purely resistive and the current is maximum.

25. (a) The intensity I of a wave is proportional to the square of its amplitude, A , i.e.,

$$I \propto A^2$$

If the amplitude becomes n times the original value, the intensity becomes m times then,

$$I' = kA'^2$$

$$mI = k(nA)^2$$

$$mI = kn^2 A^2$$

$$m = n^2$$

(b) When light falls on a surface, it exerts radiation pressure due to momentum transfer. The pressure depends on the type of surface:

Black Surface: A black body absorbs all the incident light, so the momentum transferred is

$$p = \frac{E}{c}$$

White Surface: A white body reflects all the light, so the total change in momentum is $2p$, leading to maximum pressure.

Yellow Surface: A partially reflective surface (like yellow) absorbs some light and reflects the rest, so the pressure is intermediate.

(i) **Maximum pressure:** White surface (due to full reflection)

(ii) **Minimum pressure:** Black surface (due to full absorption)

